

BIDDING/CONTRACT DOCUMENTS

APPROVED
By Alessandra at 10:14 am, Sep 16, 2021

For The “US 30 Greenway Pump Station Replacement” Project



®

Bid No. S-5-22

BID OPENING: Friday, October 15, 2021 at 2:00 p.m.

In the
City Purchasing Office
Room 307, Municipal Building
2101 O'Neil Avenue
Cheyenne, WY 82001

Inquiries Regarding This Bid Should Be Directed To:

City of Cheyenne, Purchasing Manager, TJ Barttelbort
Phone: (307) 773-1045, Email: tbarttelbort@cheyennecity.org

INVITATION FOR BID
#S-5-22

TABLE OF CONTENTS

PART 1 – INVITATION FOR BIDS 3

PART 2 - INSTRUCTIONS TO BIDDERS 4

PART 3 – PROPOSAL FORMS 14

PART 4 - NOTICE OF AWARD, NOTICE TO PROCEED, AND OTHER FORMS..... 21

PART 5 - AGREEMENT AND PERFORMANCE PAYMENT BONDS..... 30

PART 6 – GENERAL CONDITIONS 35

PART 7 - SPECIFICATIONS 49

ADMINISTRATIVE INSTRUCTIONSEND OF BOOK

FY 2022

PART 1 – INVITATION FOR BIDS

CITY OF CHEYENNE, WYOMING

	<u>CITY OF CHEYENNE</u> <u>INVITATION FOR BIDS</u>
NAME OF JOB:	US 30 Greenway Pump Station Replacement
BID NUMBER:	S-5-22

The Governing Body of the City of Cheyenne, Wyoming (“the Governing Body”) will receive sealed bid proposals at the Office of the City Purchasing Agent, located in Room 309 of the Municipal Building at 2101 O’Neil Avenue, Cheyenne, WY 82001, until 2:00 p.m. local time on the 15th day of October, 2021, for the “**US 30 Greenway Pump Station Replacement**” project.

At the aforementioned time and place, such bids that are received for the project shall be publicly opened and read aloud.

The work to be performed will be in accordance with the plans and specifications on file in the City Purchasing Agent’s office. Bidding documents may be downloaded online at <https://www.cheyennecity.org/Bids-and-Proposals>.

An optional pre-bid meeting will be held at 9:00 AM, on Thursday, September 30, 2021, in Room 208 of the Municipal Building at 2101 O’Neil Ave, Cheyenne, WY.

A bid guarantee in the amount of five percent (5%) of the total bid shall accompany any bid submitted. *See* Section 8.00 of Instructions to Bidders. The successful bidder shall furnish and pay for satisfactory performance and payment bonds in the amount of one hundred percent (100%) of the accepted bid. *See* Section 19.00 of Instructions to Bidders.

The City of Cheyenne (“the City”) reserves the right to reject any or all bids or to waive any formalities in the bidding.

Prior to the award of the contract, the City may hold bids for a period not to exceed sixty (60) calendar days from the date of opening of bids for the purpose of reviewing the bids and investigating the qualifications of the bidders. Provisions of Wyo. Stat. § 15-1-113, incorporated by reference, are made an express part of the Contract Documents.

TJ Barttelbort
Purchasing Division

Publication Dates: September 22 & 29, 2021
Published in: Wyoming Tribune Eagle

PART 2 - INSTRUCTIONS TO BIDDERS

CITY OF CHEYENNE, WYOMING

1.00 USE OF SEPARATE BID FORMS

These Contract Documents include a complete set of bidding and contract forms which are for the convenience of bidders. Bidders shall make proposals upon the forms furnished herein and pursuant to the instructions and requirements set forth herein.

2.00 INTERPRETATION OF DOCUMENTS

The City will not provide oral interpretations to any bidder as to the meaning of the Contract Documents or any part thereof. If any person contemplating submitting a proposal requires interpretation or clarification regarding the meaning of any part of the drawings, specifications, or other portions of the contract documents, or finds discrepancies in or omissions from the drawings or specifications, that bidder shall submit a written request for interpretation, clarification, or correction thereof to the City of Cheyenne, hereinafter "City". The bidder submitting the request will be responsible for its prompt delivery. Questions shall be directed to the City Purchasing Manager, by e-mail at tbarttelbort@cheyennecity.org.

Questions will be received until 5:00 pm local time on Wednesday, October 6, 2021, after which no additional questions will be accepted.

The City will respond via Addendum, no-later-than 5:00 pm local time on Friday, October 8, 2021.

3.00 ADDENDA

The City will make every interpretation, clarification, or correction to bidders by written addendum to the Contract Documents. The City will make reasonable efforts to mail, e-mail, or fax addenda to persons identified on the City's plan-holders list, but it shall be the bidder's responsibility to make inquiry as to the addenda issued. It shall also be the bidder's responsibility to confirm that it is included on the City's plan-holders list. The bidder shall acknowledge all addenda issued during the time of bidding in the bid proposal and shall be made a part of the Contract. The City will consider as incomplete any bid proposal in which all addenda are not acknowledged.

4.00 DEFINITIONS AND TERMS

Contract Documents: All documents in the bidding packet, including addenda, as identified in Part V, Article 5.

Contract Modification: A written document that must, at minimum, be executed by the Contractor and by the Mayor of the City of Cheyenne. A Contract Modification may require the approval of the City's Governing Body. A contract modification must be executed to change the Contract Price, Contract Time, or to otherwise modify the Contract Agreement.

Contract Price: The original amount bid by the contractor, as specified in Article 4 of the Agreement and modified by any Contract Modifications.

Contract Time: Begins upon the date specified in the Notice to Proceed and consists of the number of calendar days up to and including the date specified in Part V, Article 3.

Field Order: A form issued by the City Engineer (“Engineer”) to authorize the Contractor to proceed with changes or additions to the work as described in a Work Directive or a Request for Adjustment. A Field Order may either increase or decrease quantities or authorize work for payment under a Force Account, if included in the bid, but cannot increase the Contract Price.

Force Account: A method of payment for work performed by the Contractor at the Engineer’s discretion and calculated in accordance with Part VI, Section 14.

Request for Adjustment: A form issued by the Engineer to allow the Contractor to request an adjustment of the Contract Time, the Contract Price, or to request any other modification of the Contract Agreement. The Contractor shall also use this form for submitting pricing as a result of a Work Directive.

Work Directive: A form issued by the Engineer to inform the Contractor of a change in the Work which does not alter the Contract Time, the Contract Price, or any other provisions of the Contract Agreement. If a change in the Work will increase the Contract Price, the City must approve and execute a Contract Modification before the Contractor may proceed with the Work as modified.

5.00 SITE INSPECTION AND CONTRACT DOCUMENTS EXAMINATION

Each bidder shall visit the proposed work site and become acquainted with the existing conditions of the site. Then, in preparing and submitting bids, contractors should take into account the observed existing conditions, construction necessities, required labor, facilities involved, and difficulties and restrictions that may be encountered in contract performance. If possible, the City will conduct a tour of the work areas. All interested parties should contact **Wes Bay in the City’s Engineering Office, at 307-638-4315.**

Each bidder should also thoroughly examine and become familiar with the Drawings, Technical Specifications, and all other Contract Documents.

The selected bidder, by executing a contract, shall in no way be relieved of any obligation under it due to the selected bidder’s failure to review or examine any form, legal instrument, or to become acquainted with existing conditions in the work area. The City will be justified in rejecting any claim based on facts which the selected bidder knew or should have been aware of as a result of inspecting the site and Contract Documents.

6.00 ALTERNATE BIDS

The City **will not consider** alternate bids unless alternate bid items are specifically requested by the Specifications and the bid proposal.

7.00 BID PROPOSAL REQUIREMENTS

Bidders shall submit all bids on forms supplied by the City, and all such bids are subject to the Contract Documents requirements. All bids shall be regular in every respect. The bidder shall not make or include any interlineation, excisions, or special conditions in the bid forms. The bidder shall explain or note, in conjunction with its signature, any erasures or other changes in the bids.

The bidder shall submit bid documents, including the Bid Proposal, Bid Guarantee, Non-Collusion Affidavit of Prime Bidders, and Sub-Contractors and Material Suppliers List, and all other required forms, to the City Purchasing Division in a sealed envelope. The envelope shall bear the bidder's name and address, the project name, bid number, and the date and time of bid opening in order to guard against premature opening of the bid proposal.

The City may consider as irregular any bid on which there is an alteration of or departure from the bid form provided and, at its option, may reject the bid.

Award of a contract resulting from this bid will be based on Section 15.00 below.

The bidder shall correctly fill in the blank spaces on the proposal form and state the unit or lump sum prices in the spaces provided. All proposals shall be totaled, and in the case of errors or discrepancies, the unit or lump sum prices shall govern.

Each bidder shall sign and display the name and address of the bidder in the blank spaces provided. If the bid is made by a sole proprietorship or partnership, the name and address of the sole proprietorship or partnership shall be shown, together with the names and addresses of the proprietor or partners. If the proposal is made by a corporation or other business entity, an official who is authorized to bind the corporation or other business entity shall sign in the name of such corporation or business entity.

The City will consider as incomplete and may reject any bid not displaying the information required by this Section.

City representatives and the successful bidder shall hold a pre-construction conference upon contract award. This conference will be for the purpose of reaching a complete understanding with the successful bidder concerning quality of work expected, work schedule and time of completion, work progress, and coordination of all construction.

8.00 BID GUARANTEE

Each bid proposal shall be accompanied by a bid guarantee which shall not be less than five percent (5%) of the bid amount.

The 5% bid guarantee may be in the form a bid bond secured and issued by a surety or guaranty company authorized to do business in the State of Wyoming or a cashier's check made payable to the City of Cheyenne. Cash deposits, personal checks or company checks (unless certified) will not be accepted.

If the bid guarantee is to be submitted in the form of a bid bond, bidders must use the attached bid bond form. No deviation from the attached form will be allowed. If a surety company's bid bond form is used, the wording shall be exactly as shown on the City's bid bond form. No bid will be considered unless it is accompanied by the required guarantee. The bid guarantee shall ensure the execution of the agreement. The successful bidder shall furnish a surety bond as required by the Contract Documents.

If the Contractor (i) withdraws the bid within sixty (60) calendar days after bid opening, (ii) fails to provide performance and payment bonds, (iii) or fails to provide the minimum insurance certificates within the time required by Wyo. Stat. § 15-1-113 after the City accepts the proposal, then the bidder shall be liable to the City for default in the amount set forth on the bid bond as liquidated damages for said default.

Bid guarantees of unsuccessful bidders will be returned as soon as practicable after bid proposals are opened.

9.00 COLLUSIVE AGREEMENTS

Each bidder submitting a bid to the City for any portion of the work contemplated by the documents on which bidding is based shall execute and attach thereto an affidavit substantially in the form herein provided to the effect that he or she has not colluded with any other person, firm, or corporation in regard to any bid submitted.

10.00 STATEMENT OF BIDDER QUALIFICATIONS

Each bidder shall, upon the City's request, submit satisfactory evidence that the bidder has practical knowledge of the particular work being bid upon, and has the necessary financial resources required to complete the proposed work. In awarding the contract, the City will give due consideration to the ability, reliability, work load, and general reputation of each bidder, as well as the City's past experience with the bidders.

Each bidder, upon the City's request, shall show that prior work performed by the bidder has been handled in such a manner that there are no just or proper claims against such work.

No bid proposal will be acceptable if the bidder is engaged in any other work which impairs his or her ability to finance this contract or provide equipment for the proper execution of the contract.

11.00 UNIT PRICES

If unit prices are called for, the unit price of each item in the proposal shall include the *pro rata* share of overhead and profit. As such, the sum of the products obtained by multiplying the quantity shown for each item by the unit price bid equals the total bid. The City may reject as irregular any bid not conforming to this requirement. Bidders should pay special attention to this provision.

If conditions make it necessary to revise bid quantities, no limit will be fixed for such quantity revisions, provided the net cash value of all such additive and subtractive changes

shall not change the original, total contract price by more than twenty percent (20%). The quantities appearing on the proposal form are approximate and are prepared for the comparison of bids. Payment to the contractor will be made only for the actual, accepted quantities of work performed and materials furnished in accordance with the contract.

The presence of any unit bid price that generates reasonable doubt that award to that bidder would result in the lowest ultimate cost to the City may be rejected as irregular.

12.00 TIME FOR RECEIVING BIDS

Bid proposals received before the advertised time for opening bids will be kept securely sealed until the time arrives to open bids. The officer whose duty it is to open bids will decide when the specified time has arrived, and no bid received thereafter will be considered.

13.00 BID OPENING

At the time and place fixed for opening bids, the City will open and publicly read aloud every bid received within the time set for receiving bids, irrespective of any irregularities therein. Bidders and other persons properly interested may be present in person or by representative.

14.00 BID WITHDRAWAL

Bids may be withdrawn by written or faxed request at any time prior to the scheduled closing time for receipt of proposals.

15.00 CONTRACT AWARD AND BID REJECTION

The City will award the contract to the most qualified and responsible bidder, as determined in the City's sole discretion, who submits the lowest total responsive bid shown on Itemized Bid Sheet "A" plus "B". This bid must also be less than funds available for this project. The City reserves the right to reject a bid if the total bid shown on the last Itemized Bid Sheet is not identical to the total bid shown on the Bid Proposal Sheet, included in this Bid Packet. The City reserves the right to reject a bid if the total bid price shown on the last Itemized Bid Sheet is not calculated correctly.

The City reserves the right to reject any or all proposals or to waive any formality or irregularity in any proposal in the interest of the City. No bidder may withdraw his proposal for a period of sixty (60) calendar days after the date of opening thereof.

16.00 FUNDS PROGRAMMED

The funds programmed for construction are estimated to be sufficient to provide for the proposed work shown on the plans. In the event contract unit prices indicate a total cost of the project in excess of the allotted funds, the project length may be shortened or quantities decreased to keep the cost of work within the funds allocated to the project. Similarly, if the contract unit prices indicate a total cost of the project less than the allotted

funds, the length of the project may be increased and quantities added to ensure the allotted funds for the project are used.

17.00 PREFERENCE FOR STATE LABOR AND MATERIALS

Pursuant to Wyo. Stat. § 16-6-104, Wyoming made materials and products, and Wyoming suppliers of products and materials of equal quality and desirability shall have preference over materials or products produced or supplied outside the state and any contract let shall so provide. The City shall apply the preference created by Wyo. Stat. § 16-6-104 in a manner identical to the preference for resident contractors in Wyo. Stat. § 16-6-102.

Pursuant to Wyo. Stat. § 16-6-102, the City shall award the contract to the responsible, certified resident making the lowest responsible bid, if the certified resident's bid is not more than five percent (5%) higher than the lowest responsible, nonresident bidder.

Pursuant to Wyo. Stat. § 16-6-103, a successful resident bidder shall not subcontract more than thirty percent (30%) of the work covered by the contract to nonresident contractors.

Pursuant to Wyo. Stat. § 16-6-106, preference is hereby given to materials, supplies, agricultural products, equipment, machinery, and provisions produced, manufactured, or grown in Wyoming, or supplied by a state resident, quality being equal to articles offered by the competitors outside of the state.

Pursuant to W.S. § 16-6-107, the structure or structures to be constructed pursuant to this invitation to bidders shall be constructed and maintained by materials produced or manufactured in Wyoming if Wyoming materials are suitable and can be furnished in marketable quantities. Preference shall not be granted for materials of an inferior quality to those offered by competitors outside of the state, but a differential of five percent (5%) shall be allowed in cost of contracts Wyoming materials produced or manufactured in Wyoming.

Pursuant to Wyo. Stat. § 16-6-203, the successful bidder shall employ only Wyoming laborers on the project, and the contract awarded to the successful bidder shall contain a provision requiring that Wyoming labor be used, except other laborers may be used when Wyoming laborers are not available for employment within the state, or are not qualified to perform the work involved. In addition, the contract shall contain a provision requiring specific acknowledgement of the requirements of this section. The successful bidder may employ laborers other than Wyoming laborers if:

- (i) The successful bidder informs the nearest state workforce center of his employment needs at least eleven (11) calendar days before work is commenced;
- (ii) The state workforce center certifies that the bidder's need for laborers cannot be filled from those Wyoming laborers listed with the Wyoming Department of Workforce Services. The department shall respond to a bidder's request for certification within ten (10) calendar days of the date the information is filed; and

- (iii) The successful bidder shall also agree to promptly respond to requests from the Wyoming Department of Workforce Services for the most recent construction schedule for the project.

18.00 CERTIFICATE OF RESIDENCY STATUS FOR IN-STATE PREFERENCE

Wyoming Contractors desiring residency status for the purpose of obtaining the five percent (5%) preference for resident bidders on public works projects must be so certified by the Wyoming Department of Workforce Services. No bidder may be considered a resident for the purpose of the five percent (5%) preference unless his residency has been certified as provided in Wyo. Stat. § 16-6-101.

19.00 AGREEMENT EXECUTION, PERFORMANCE, AND PAYMENT BONDS

Subsequent to the award and within fifteen (15) calendar days after the prescribed forms are presented for signature, the successful bidder shall execute and deliver to the City an agreement in the form included in the Contract Documents in such number of copies as the City may require and at the same time shall also provide the insurance, Workers Compensation and Unemployment insurance certificates, and the performance and payment bonds. The performance and payment bonds will remain active for the two (2) year warranty period, which is the two (2) year period following the City's acceptance of the substantial completion certificate. If the Contractor is required to perform corrections in the work of the project in the two (2) year warranty period, the Contractor shall provide copies of their current insurance, Worker's Compensation, and Unemployment Insurance Certificates as required in the original project.

Having satisfied all conditions of award as set forth elsewhere in these documents, the successful bidder shall, within the period specified in paragraph "a." above, furnish a surety bond, not less than the amount of the contract as awarded, as security for the faithful performance of the contract and a bond in an equal sum as surety for the payment of all persons, firms, or corporations to whom the successful bidder may become legally indebted for labor, materials, tools, equipment, or services of any nature, including utilities and transportation services employed or used by him in performing the work. Such bond or bonds shall be in the same form as that included in the Contract Documents and shall bear the same date as that of the agreement. The current power of attorney for the person who signs for any surety company shall be attached to such bonds. These bonds shall be signed by an authorized agent of the surety company qualified to do business in the State of Wyoming. The successful bidder shall notify the surety of any changes affecting the general scope of the project or change in the Contract Price, and the amount of the bonds shall be adjusted accordingly. The successful bidder shall furnish proof of such adjustment to the City.

The successful bidder's failure to execute such agreement, or to supply the required bond or bonds within thirty (30) calendar days after the prescribed forms are presented for signature, or within such extended period as the City may grant based upon reasons determined sufficient by the City, shall constitute a default. The City may then award the contract to the next lowest, responsible bidder or re-advertise for bids, and the bid guarantee of the bidder shall be forfeited to the City as liquidated damages as per Wyo. Stat. § 15-1-113(f). The City may also charge against the defaulting bidder the additional

difference between the amount of the original low bid and the amount for which the contract is subsequently let, if the amount exceeds the amount of the bid bond. If a more favorable bid is received by re-advertising, the defaulting bidder shall have no claim against the City for a refund.

If the cost of a payment and performance bond is included in the bid, the successful bidder may receive reimbursement for the costs of the bonds subject to the following requirements. If the bond cost is not included as a bid item, the bond cost shall be deemed to have been included in the Contract Price.

Subsequent to the contract award and compliance with the conditions stated in the preceding paragraph, the successful bidder may submit a written request to the engineer in charge of the project requesting the payment and performance bid item. The successful bidder shall include with this written request, a statement from the insuring firm, indicating the bond cost based on the preliminary estimate of the cost of the contract or as adjusted by the final contract price. Payment for the bond cost will be computed on the basis of the final Contract Price or on the basis of the preliminary cost estimate of the contract, whichever is less. The payment for a payment and performance bond may be adjusted upon project completion based on approved modifications to the Contract Price.

20.00 SALES AND USE TAX PROVISIONS

The successful bidder shall abide by Wyo. Stat. § 39-15-101 *et seq.*, and Wyo. Stat. § 39-16-101 *et seq.*, relating to Sales and Use Taxes. In particular, the successful bidder shall abide by the guidance provided in State of Wyoming, Department of Revenue Bulletin, “Use Tax and You” issued December 5, 2012, revised July 1, 2014. This Bulletin is available on-line through the Wyoming Department of Revenue’s website. If the Contractor has difficulty locating the Bulletin, they may contact the Wyoming Department of Revenue for assistance.

The successful bidder shall cause all subcontractors to abide by and perform their work on the same terms and conditions as provided above. The successful bidder shall cause the above statements to be inserted in any contract or agreement between the successful bidder and subcontractors.

The successful bidder shall notify the Wyoming Department of Revenue, Excise Tax Division, when they begin work on any project in the State of Wyoming. The notice shall include the project name, specific project location and contract amount. Questions regarding sales and use taxes should be directed to the Wyoming Department of Revenue, Excise Tax Division at (307) 777-5204.

21.00 TRADE NAME PROVISIONS

When in the specifications or drawings, an item is identified by a manufacturer’s name, trade name, catalog number, or reference, the bidder proposes to furnish the item so identified and does not propose to furnish an “equal” unless the proposed “equal” is clearly communicated to the City by the bidder, and the bidder has obtained prior certification from the City for approval of the proposed “equal”.

The reference to a manufacturer's name, trade name, or catalog number is intended to be descriptive, but not restrictive, and only to indicate to the bidder articles that will be satisfactory. Bids on other makes, catalog numbers, etc., will be considered, provided each bidder clearly states on the bid proposal exactly what the bidder proposes to furnish, and has submitted to the City, at least seven (7) calendar days prior to the bid opening date, illustrations, specifications, or other descriptive matter which clearly indicate the character of the article(s) to be covered by the bid, and has obtained the prior approval of the City for the proposed "equal".

The City reserves the right to approve as an equal, or to reject as not being equal, any article the bidder proposes to furnish which contains major or minor variations from specifications but which may comply substantially therewith.

22.00 RETAINAGE ADMINISTRATION FOR CONTRACTS EXCEEDING \$50,000.00

The City will withhold five percent (5%) of the work's dollar value completed throughout the contract term.

If requested by the general contractor, the City shall enter into an interest bearing deposit agreement with any depository designated by the general contractor, after notice to the surety, to provide an agent for the custodial care and servicing of any deposits placed with it pursuant to this act on any contract of more than fifty thousand dollars (\$50,000.00) pursuant to Wyo. Stat. § 16-6-704. Interest income will be paid to the successful bidder as collected or as otherwise instructed by the successful bidder. All expenses incurred for this service will be charged to the successful bidder and deducted from payments due and retained funds.

If the City finds that satisfactory progress is being made in all phases of the contract it may, upon written request by the contractor, authorize payment from the withheld percentage. Before the payment is made, the public entity shall determine that satisfactory and substantial reasons exist for the payment and shall require written approval from any surety furnishing bonds for the contract work in accordance with Wyo. Stat. § 16-6-116.

No payments returning retainage from this fund will be made until the City has determined that satisfactory and substantial reasons exist for the payment, and the required Certificate of Completion; Affidavit of Release of Liens; Contractor's Final Waiver of Liens; Sub-Contractor's Final Waiver of Liens; Consent of Surety for final payment; Sworn Statement for Final Payment Pursuant to Wyo. Stat. § 16-6-116 and § 16-6-117; and Engineer's Certificate of Completion have all been received by the City, and all the items on the punch list have been completed.

23.00 SUB-CONTRACTORS, MATERIALMEN PROTECTION UNDER A BOND OR GUARANTEE; LIMITATIONS.

For contracts of \$150,000.00 or more, the Contractor shall post on the construction site a prominent sign citing Wyo. Stat. § 16-6-121 and stating that any Sub-Contractor or materialmen shall give notice to the Contractor of a right to protection under the bond or guarantee and that failure to provide the notice shall waive the Sub-Contractor or materialmen's protection under the bond or guarantee and shall waive any right to a lien

for material or services provided. The general contractor shall post on the construction site a prominent sign citing this section and stating that any subcontractor or materialman shall give notice to the general contractor of a right to protection under the bond or guarantee and that failure to provide the notice shall waive the subcontractor or materialman's protection under the bond or guarantee.

24.00 PERMITS AND LICENSES

The Contractor shall obtain all permits necessary to execute the work. Fees will be waived for permits issued by the City. Permits may be required by other entities which are not furnished or paid for by the City. The successful bidder and its subcontractors shall be required to hold and pay for any licenses required and shall also pay for all public utility charges.

25.00 PRE-BID CONFERENCE

An optional pre-bid meeting will be held at 9:00 AM, on Thursday, September 30, 2021, in Room 208 of the Municipal Building at 2101 O'Neil Ave, Cheyenne, WY.

Representatives of the City will be present to discuss the Project.

PART 3 – PROPOSAL FORMS
CITY OF CHEYENNE, WYOMING

	<p><u>CITY OF CHEYENNE BID PROPOSAL FORM</u></p>
BID NO.	S-5-22
OPEN DATE:	October 15, 2021
TIME:	2:00 PM
PROJECT:	US 30 Greenway Pump Station Replacement

TO: GOVERNING BODY
CITY OF CHEYENNE
2101 O’NEIL AVENUE
CHEYENNE, WY 82001

(Submit bids to the City Purchasing
Division, Room 309, Municipal Bldg.
at 2101 O’Neil Avenue)

- Pursuant to and in full compliance with all Bidding Documents, the undersigned Bidder hereby proposes to furnish all the labor and materials and to perform all the work required for the complete and prompt execution of everything described or shown in or reasonably implied by the Bidding Documents, including the Drawings and Specifications, for the work above indicated for the monies stated herein, which includes all State, County and local taxes normally payable in respect to such work when done for an entity not entitled to any exemption from such taxes. The amounts stated include all allowances for profit and overhead, taxes, fees and permits, transportation, services, tools and equipment, labor and materials and other incidental costs.
- The Bidder has carefully examined the Bidding Documents, including the Drawings and Specifications and the work site, and has fully apprised him/her -self of the conditions affecting the work to be executed, and hereby proposes to construct and complete the above-referenced project, all in accordance with the Bidding Documents, at and for the following sum, as reflected in the total on the attached itemized bid sheets:

_____ Dollars

(\$ _____).
- This Bid Proposal is accompanied by the required Bid Guarantee of five percent (5%) based upon the total cost of all items required to be bid. The City of Cheyenne is authorized to hold said Bid Guarantee for a period of not more than sixty (60) calendar days after the opening of the bids for the purpose of evaluating bids prior to award. If awarded the contract for this work, the undersigned Bidder agrees to execute the Agreement and furnish the required Bonds and Insurance Certificates within thirty (30) calendar days from the date of Notice of Award.
- Attached hereto is an affidavit in proof that the undersigned has not entered into a collusive agreement with any person in respect to this bid or any other bid or the submitting of bids for which this bid is submitted.

5. The undersigned bidder **has [] has not []** been granted a State of Wyoming Certificate of Residency Status. If the bidder has been granted a State of Wyoming Certificate of Residency Status, the undersigned **bidder has [] has not []** subcontracted more than thirty percent (30%) of the work covered by this contract to nonresident bidders, as per Wyo. Stat. § 16-6-103 regarding limitations on subcontracting by resident contractors.

Dated this _____ day of _____, _____
(Month) (Year)

FIRM NAME: _____

Bidder's Legal Stature: Corporation
 Partnership
 Individual Sole Proprietorship
 L.L.C.
 Other: _____

State of Incorporation: _____

Bidder's Address: _____

Telephone Number: _____

Email Address: _____

By: _____
(Bidder's Signature)

Title: _____

Witness

The Bidder acknowledges receipt of the following addenda to the Bid Documents (if none, so state): _____.

Addendum No. Dated

US 30 GREENWAY PUMP STATION REPLACEMENT

**BID TAB
BID S-5-22**

ITEM #	DESCRIPTION	UNIT	QUANTITY	UNIT PRICE	TOTAL PRICE
01000	PERFORMANCE BOND	BOND	1.00		
01000	MOBILIZATION	LS	1.00		
01000	FORCE ACCOUNT	FA	10,000.00	\$ 10,000.00	\$ 10,000.00
01050	TRAFFIC CONTROL	LS	1.00		
02725	REMOVE AND REPLACE STORM WATER PUMP STATION	LS	1.00		
03340	RELOCATE LOW WATER CROSSING	LS	1.00		
TOTAL					

COMPANY NAME: _____

ADDRESS: _____

CITY, STATE, ZIP: _____

BIDDER'S SIGNATURE: _____



**CITY OF CHEYENNE NON-COLLUSION
AFFIDAVIT OF PRIME BIDDERS FORM**

State of:	
County of:	

_____, being first duly sworn, deposes and says that:

- (1) S/he is (owner, partner, officer, representative, or agent) of _____, the bidder that has submitted the attached bid;
- (2) S/he is fully informed respecting the preparation and contents of the attached bid and of all pertinent circumstances respecting such bid;
- (3) Such bid is genuine and is not a collusive or sham bid;
- (4) Neither the said Bidder nor any of its officers, partners, owners, agents, representatives, employees, or parties in interest, including this affiant, has in any way colluded, conspired, connived or agreed, directly or indirectly with any other bidder, firm, or person to submit a collusive or sham bid in connection with the contract of which the attached bid has been submitted or to refrain from bidding in connection with such contract, or has in any manner, directly or indirectly, sought by agreement, collusion, communication, or conference with any other bidder, firm or person to fix the price or prices in the attached bid or of any other Bidder; to fix any overhead, profit, or cost element of the bid price or the bid price of any other Bidder; or to secure through any collusion, conspiracy, connivance, or unlawful agreement any advantage against the City or any person interested in the proposed contract; and
- (5) The price or prices quoted in the attached bid are fair and proper and are not tainted by any collusion, conspiracy, connivance, or unlawful agreement on the part of the bidder or any of the bidder's agents, representatives, owners, employees, or parties in interest, including this affiant.

Signed _____

Subscribed and sworn to before me this _____ day of _____, _____.

(Title) (Signature)

My Commission expires _____



CITY OF CHEYENNE BID BOND FORM

PROJECT	US 30 Greenway Pump Station Replacement
BID NUMBER	S-5-22

KNOW ALL MEN BY THESE PRESENTS, that _____, as Principal, and _____, as Surety, a corporation duly organized under the laws of the State of _____ and authorized to do business within the State of Wyoming, are held and firmly bound unto the City of Cheyenne, Wyoming, in the full and just sum of _____ Dollars (\$_____), lawful money of the United States, for the payment of which sum, well and truly to be made, we bind ourselves, our heirs, executors, administrators, successors and assigns, jointly and severally, firmly by these presents.

WHEREAS, said Principal is herewith submitting a Proposal for _____, and the City of Cheyenne, Wyoming has required as a condition for submitting said Proposal, that said Principal deposit specified Bid Security in an amount not less than five percent (5%) of the amount of said Proposal, conditioned that in event of failure of Principal to execute the contract and furnish the required performance and payment bonds if the contract is awarded to said Principal, that said sum be paid immediately to the City of Cheyenne, Wyoming as liquidated damages, and not as penalty, for the Principal's failure to perform.

The condition of this obligation is such that if the aforesaid Principal will, within the time required, enter into a formal contract and give such bonds as are specified in the bidding documents with surety acceptable to the City; or if Principal shall fail to do so, pay to the City the sum determined herein as liquidated damages and not as a penalty, then this obligation shall be void; otherwise to remain in full force and effect.

Signed, sealed, and delivered this _____ day of _____, _____.

Witness

Principal (seal)

by _____

Title _____

Witness

Surety (seal)

by _____

Attorney-in-fact

(Attach Power of Attorney)



CITY OF CHEYENNE SUBCONTRACTORS AND MATERIALS SUPPLIERS LIST FORM

BIDDER'S NAME

List all materials suppliers and subcontractors proposed for this project and return list with bid:

ATTENTION!

Any Resident Bidder using Non-Resident subcontractors must fill in the percentage of work being done by the subcontractor.

WORK	SUBCONTRACTOR OR MATERIAL SUPPLIER	CITY/STATE	% OF WORK

BID SUBMISSION CHECKLIST

THE FOLLOWING CHECKLIST REPRESENTS THE REQUIRED FORMS TO BE EXECUTED AND DOCUMENTS TO PREPARE. THESE FORMS AND DOCUMENTS ARE TO BE INCLUDED IN THE CONTRACTOR'S SUBMITTED BID PACKAGE.

COMPLETED & INCLUDED

- | | |
|--|-----|
| 1. City of Cheyenne Bid Proposal Form | [] |
| 2. Bid Price Total | [] |
| 3. Itemized Bid Schedule | [] |
| 4. Sub-Contractors and Material Suppliers List | [] |
| 5. Non-Collusion Affidavit of Prime Bidders | [] |
| 6. Bid Security / Bid Guarantee | [] |
| 7. Acknowledgement of Addenda (If Any) | [] |

PART 4 - NOTICE OF AWARD, NOTICE TO PROCEED, AND OTHER FORMS
CITY OF CHEYENNE, WYOMING

	<p><u>CITY OF CHEYENNE</u> <u>BID ACCEPTANCE FORM</u></p>
BID NUMBER:	S-5-22
DATE:	
TO:	

To Whom It May Concern:

The City of Cheyenne, having duly considered the proposals submitted on ___/___/___ for the construction of **“US 30 Greenway Pump Station Replacement”**, as outlined in these Contract Documents, and it appearing that your Proposal for performing the work outlined is fair, equitable, and in the City’s best interest, the bid items are hereby accepted at the bid prices contained therein.

In accordance with the terms of these Contract Documents, you are required to execute the formal Agreement and furnish the required Performance and Payment Bonds within thirty (30) calendar days from and including the date of this notice.

In addition, you are required to furnish at the same time a copy of Certificate of Insurance evidencing compliance with the requirements for insurance stated in the Bidding Documents, including unemployment insurance, and a copy of your Worker’s Compensation Certificate.

The Bid Guarantee submitted with your Proposal will be retained until the Agreement has been executed and the required Performance and Payment Bonds have been furnished and approved. In event that you should fail to execute the contract and furnish the Performance and Payment Bonds within the time limit specified, the said bid security will be retained as liquidated damages and not as penalty for the delay and extra work caused thereby.

CITY OF CHEYENNE, WYOMING

By _____
Purchasing Manager



CITY OF CHEYENNE
NOTICE TO PROCEED FORM

BID NUMBER:	S-5-22
DATE:	
TO:	

You are hereby authorized to proceed on this date, _____ with the construction of **“US 30 Greenway Pump Station Replacement”** as set forth in detail in the Contract Documents. No work may be done at the site prior to the date stated above.

CITY OF CHEYENNE, WYOMING

By _____
Purchasing Manager

The Contractor is required to return an acknowledged copy of this Notice to the City.

Acknowledged:

Contractor:	
By [Printed Name]:	
By: [Signature]:	
Title:	
Date:	



**CITY OF CHEYENNE CONTRACTOR'S
CERTIFICATION OF COMPLETION FORM**

DATE:	
PROJECT:	US 30 Greenway Pump Station Replacement
JOB NUMBER:	
CONTRACT NUMBER:	
OWNER:	
FROM:	

This is to certify that I, _____, am an authorized official of _____, working in the capacity of _____, and have been properly authorized by said firm or corporation to sign the following statements pertaining to the subject contract:

I know of my own personal knowledge, and do hereby certify, that the work of the contract described above has been performed, and materials used and installed in every particular, in accordance with, and in conformity to, the contract drawings and specifications.

The contract work is now complete in all parts and requirements, and ready for your final inspection.

I understand that neither the determination by the Engineer/Architect that the work is complete, nor the acceptance thereof by the Owner, shall operate as a bar to claim against the Contractor under the terms of the guarantee provisions of the Contract Documents.

BY: _____

TITLE: _____

FOR: _____



CITY OF CHEYENNE
CONSENT OF SURETY FOR FINAL
PAYMENT FORM

PROJECT NAME:	US 30 Greenway Pump Station Replacement
LOCATION:	
PROJECT NUMBER:	S-5-22
TYPE OF CONTRACT:	
AMOUNT OF CONTRACT:	

In accordance with the provisions of the above-named contract between the Owner and the Contractor, the following named surety:

On the Payment Bond of the following named Contractor:

hereby approves of final payment to the Contractor, and further agrees that said final payment to the Contractor shall not relieve the Surety Company named herein of any of its obligations to the following named Owner as set forth in said Surety company's bond:

IN WITNESS WHEREOF, the Surety Company has hereunto set its hand and seal this _____ day of _____, _____.

(Name of Surety Company)

(Signature of Authorized Representative)

(Affix corporate seal here)

Title _____



CITY OF CHEYENNE
FINAL WAIVER OF LIEN
FORM

(Instructions at bottom of form)

TO ALL WHOM IT MAY CONCERN:

WHEREAS, the undersigned has been employed by	
A.	
to furnish labor and materials for	
B.	
work, under a contract	
C.	
for the improvement of the premises described as	
D.	
in the City of Cheyenne, Laramie County, Wyoming, of which the City of Cheyenne is the Owner.	

NOW, THEREFORE, this ____ day of _____, _____, for and in consideration of the sum of	
E.	
dollars, paid simultaneously herewith, the receipt whereof is hereby acknowledged by the undersigned, the undersigned does hereby waive and release any lien rights to, or claim of lien with respect to and on said above-described premises, and the improvements thereon, and on the monies or other considerations due or to become due from the owner, on account of labor, services, material, fixture, apparatus or machinery heretofore or which may hereafter be furnished by the undersigned to or for the above described premises by virtue of said contract.	

(F) _____ (SEAL)
 (Name of sole ownership, corporation or partnership)

 (Signature of Authorized Representative)

TITLE: _____

INSTRUCTIONS FOR FINAL WAIVER:	
A.	Person or firm with whom you agreed to furnish either labor, or services, or materials, or both.
B.	Fill in nature and extent of work; strike the word labor or the word materials if not in your contract.
C.	If you have more than one contract on the same premises, describe the contract by number if available, date and extent of work.
D.	Furnish an accurate enough description of the improvement and location of the premises so that it can be distinguished from any other property.
E.	Amount shown should be the amount actually received and equal to total amount of contract as adjusted.
F.	If waiver is for a corporation, corporate name should be used, corporate seal affixed and title of officer signing waiver should be set forth; if waiver is for a partnership, the partnership name should be used, partner should sign and designate himself as partner.



CITY OF CHEYENNE
AFFIDAVIT OF RELEASE OF LIENS
FORM

TO ALL WHOM IT MAY CONCERN:

WHEREAS, the undersigned has been employed by _____ to furnish labor and materials for _____ work, under a contract _____ for the improvement of the property described as _____

in the city/town of _____, County of _____, State of _____ of which _____ is the Owner.

NOW, THEREFORE, this _____ day of _____, _____, the undersigned, as the Contractor for the above-named contract pursuant to the conditions of the contract hereby certifies that to the best of his knowledge, information and belief, except as listed below, the Releases or Waivers of Lien attached hereto include the Contractor, all Subcontractors, all suppliers of materials and equipment, and all performers of work, labor or services, who have or may have liens against any property of the Owner arising in any manner out of the performance of the contract referenced above.

Exceptions: (List names of suppliers and/or subcontractors and amounts owed. If none, write "None.") The City will withhold the amounts listed below from final payment due the Contractor until these obligations have been satisfied.

CONTRACTOR _____ (SEAL)
(Name of sole ownership, corporation or partnership)

(Affix corporate seal here) _____ (SEAL)
(Signature of Authorized Representative)

TITLE: _____

ATTACHMENTS:

- 1. Contractor's Release or Waiver of Liens, conditional upon receipt of final payment.
- 2. Separate Releases or Waivers of Liens from Subcontractors and material and equipment suppliers.



CITY OF CHEYENNE
AFFIDAVIT OF PAYMENT
FORM

TO ALL WHOM IT MAY CONCERN:

WHEREAS, the undersigned has been employed by _____ to furnish labor and materials for _____ (work) under contract # _____ for the improvement of the property described as _____ in the city/town of _____, County of _____, State of _____ of which _____ is the Owner.

NOW, THEREFORE, this ____ day of _____, _____, the undersigned, as the Contractor for the above-named Contract pursuant to the Conditions of the Contract hereby certifies that, except as listed below, he has paid in full or has otherwise satisfied all obligations for all materials and equipment furnished, for all work, labor, and services performed, and for all known indebtedness and claims against the Contractor for damages arising in any manner in connection with the performance of the Contract referenced above for which the Owner or his property might in any way be held responsible.

EXCEPTIONS: (If none, write "None." If required by the Owner, the Contractor shall furnish bond satisfactory to the Owner for each exception.)

ATTACHMENTS:

- I. Consent of Surety to Final Payment. (Whenever Surety is involved, Consent Of Surety is required.)
- II. Contractor's Release or Waiver of Liens, conditional upon receipt of final payment.
- III. Separate Releases or Waivers of Liens from Subcontractors and material and equipment suppliers.
- IV. Contractor's Affidavit of Release of Liens.

CONTRACTOR _____ (SEAL)
(Name of sole ownership, corporation or partnership)

(Affix corporate seal here) _____ (SEAL)
(Signature of Authorized Representative)

TITLE: _____



CITY OF CHEYENNE
CONTRACT PAYMENT REQUEST
FORM

DATE:	
PROJECT:	US 30 Greenway Pump Station Replacement
CITY BID NUMBER:	S-5-22
CITY CONTRACT NUMBER:	
CONTRACTOR:	
CONTRACT PAYMENT REQUEST NUMBER:	
FOR WORK COMPLETED THROUGH DATE OF:	

The present status of the account for this contract is as follows:

Original Contract Amount	\$
Net Change by Change Orders to Date	\$
Current Contract Amount	\$
Total Completed to Date	\$
Less 5% Retainage	\$
Total Earned Less Retainage	\$
Less Previous Payments	\$
Total Payment Due	\$
Total Retainage Due	\$

Contractor's Certification:

The undersigned Contractor certifies that: (1) all previous progress payments received from the City on account of work done under the Contract referred to above have been applied to discharge Contractor's legitimate obligations incurred in connection with work covered by prior Contract Payment Request numbered one through ____ inclusive: (2) title of all work, materials and equipment incorporated in said work or otherwise listed in or covered by this Contract Payment Request will pass to Owner at the time of payment free and clear of all Liens, security interests and encumbrances (except such as are covered by Bond acceptable to owner indemnifying Owner against such liens, security interest or encumbrance); and (3) all work covered by this Contract Payment Request is in accordance with the Contract Documents and not defective.

Date

Contractor

Authorized Signature

Print Name and Title

Payment of the above AMOUNT DUE THIS PAY REQUEST is recommended.

Project Manager Signature

Print Name and Title

Authorization by City Representative

City Representative Signature

Print Name and Title



CITY OF CHEYENNE
ITEMIZED PAY REQUEST
FORM

CONTRACTOR:

PROJECT:

US 30 Greenway Pump Station Replacement

PAY REQUEST NUMBER:

This form must be submitted with the above pay request, or submit AIA document G702 and G703.

A	B	C	D	E	F	G	H	I	J	K
					Work Completed					
Description of Work/Material	Unit	Original QTY	Contract Unit Price	Original Contract Price	QTY Complete This period	Total Complete This period	QTY Complete from Previous Period	Total Complete From Previous Period	Total Complete (G+I)	Balance to finish

Signature: _____

Print Name: _____

PART 5 - AGREEMENT AND PERFORMANCE PAYMENT BONDS
CITY OF CHEYENNE, WYOMING

	<u>CITY OF CHEYENNE</u> <u>AGREEMENT FORM</u>
BID NUMBER:	S-5-22
CONTRACT NUMBER:	

THIS AGREEMENT, entered into this ____ day of _____, _____, by and between the CITY OF CHEYENNE, WYOMING, hereinafter referred to as the “CITY”, and _____, hereinafter referred to as the “CONTRACTOR”.

WITNESSETH that the Contractor and the City, for the considerations stated herein, mutually agree as follows:

ARTICLE 1. STATEMENT OF WORK. The Contractor shall furnish all supervision, technical personnel, labor, materials, machinery, tools, equipment, and services, including utility and transportation services, and perform and complete all work in an efficient and workmanlike manner in the construction of the “**US 30 Greenway Pump Station Replacement**” project all in strict accordance with the Contract Documents including all addenda thereto, numbered and dated:

ARTICLE 2. RESPONSIBLE DESIGNEE FOR THE CITY. The Contractor shall in any and all matters relating to the scope of services to be provided under this Contract or any other provisions herein, contact the City Engineer, or his/her designated representative.

ARTICLE 3. TIME FRAME FOR COMPLETION. The services to be performed under this Agreement shall commence on the date stipulated in the “Notice to Proceed” that will be issued by the City. The work shall be completed by _____. If the work has not been completed within the time stipulated above, including any extensions of time issued by the City for excusable delays, the Contractor and his/her sureties shall pay the City fixed, agreed liquidated damages, as stipulated in the Supplemental Conditions, for each calendar day of delay until the work is completed.

ARTICLE 4. COMPENSATION AND METHOD OF PAYMENT. The CITY will pay the Contractor for the performance of the Contract in current funds, the sum of _____ Dollars (\$_____). In the event there are changes in the estimated quantities shown on the Bid Proposal, the unit prices multiplied by the actual quantities shall govern, and the total contract amount will be adjusted accordingly. The City agrees to pay the above amount for contractual services in the following manner, upon receipt of appropriate documentation:

- a. The Contractor will be paid on a monthly basis for percentage of estimated work completed. Submittal will be at least seven (7) business days prior to the payable due date as established annually by the City Treasurer’s Office. The pay request shall be submitted on the Contract

Payment Request Form and Itemized Pay Request or the AIA Documents G702 and G703. The engineer will review the estimate for approval prior to payment.

- b. The City will withhold five percent (5%) of the dollar value of the work completed for a minimum of forty-one (41) calendar days after Notice of Final Settlement has been published in accordance with Wyo. Stat. §15-1-113(h). Upon completion of the work under this Contract, the Contractor shall submit a Contractor’s Certificate of Completion; the Consent of Surety; Final Waivers of Lien from the Contractor, and all Sub-Contractors, Suppliers and Materialmen; Affidavit of Release of Liens; Affidavit of Payment; and a current Workers Compensation Certificate. Final payment will not be made until the above documents have been received by the City and all items on the Punch List have been completed, and the advertising requirements have been met.

ARTICLE 5. CONTRACT. The executed Contract Documents shall consist of the following:

- 1. This Agreement;
- 2. Addenda;
- 3. Invitation for Bids;
- 4. Instructions to Bidders;
- 5. Signed Bid Proposal;
- 6. General Conditions and Insurance;
- 7. Supplemental Conditions;
- 8. Part IV Forms & Notices;
- 9. Specifications and Special Provisions;
- 10. Drawings.

This Agreement, together with other documents enumerated in this Article 5, which said other documents are as fully a part of the Contract as if hereto attached or herein repeated, forms the Contract between the parties hereto.

IN WITNESS WHEREOF, THAT the governing body of the City of Cheyenne has authorized the Mayor as Executive Officer of the City to enter into this Agreement, and that the parties hereto have caused this Agreement to be executed on the day and year in the first part herein written.

ATTEST:

CITY OF CHEYENNE, WYOMING

Kristina F. Jones, City Clerk

Patrick Collins, Mayor

Notary or Corporation Secretary:
SUBSCRIBED AND SWORN TO BEFORE ME
this ___ day of _____, ____
by _____
My Commission expires: _____

Contractor
By _____

Title

Address



CITY OF CHEYENNE
PERFORMANCE AND PAYMENT
BOND REQUIREMENTS

1.	Signature of principal must be affixed to the bond.
2.	Signature of principal must be witnessed.
3.	Name of principal must be witnessed.
4.	The legal capacity of the principal must be stated in the caption of the bond (i.e., corporation, partnership or sole proprietorship).
5.	If the principal is jointly owned, all owners must sign the bond.
6.	If the principal is a partnership, at least two partners must sign the bond.
7.	Signature of the attorney-in-fact acting on behalf of the surety company must appear on the bond.
8.	The surety's seal must be affixed to the signature of the attorney-in-fact (Facsimile seals are NOT acceptable).
9.	The surety company must be registered with the state insurance commission and qualified to do business in the State of Wyoming.
10.	Power of Attorney/Acknowledgment of Surety must be signed, sealed and dated with the same date as execution of bond.
11.	Date of written Agreement and date of bond must be same. Post-dated bonds are not acceptable.
12.	Bond form must be completely executed. Bonds with blank spaces, including dates, are unacceptable.
13.	The bond must be accompanied by a properly executed authorization of Power of Attorney. Note: The bond shall continue in force throughout the project and a two-year warranty period; and at the discretion of the City, for any additional warranty period specified in the contract documents.
CORPORATE PRINCIPALS ONLY	
14.	The person signing on behalf of the corporate principal must state his/her legal capacity and he/she must be either the president or the vice-president if it is a corporation. If the officer or person signing on behalf of the corporate principal is other than the president or vice-president, there must be attached to the bond a resolution or certified evidence of authority that such officer or person has authority to sign in behalf of the principal.
15.	The signature of the principal must be witnessed, or attested to if it is a corporate principal by ONLY the secretary or assistant secretary of the corporation.
16.	The corporate seal must be affixed to the signature of the principal. (Facsimile seals are NOT accepted).
17.	Each party is required to sign his/her own name.
18.	All changes or strike-throughs must be initialed by the resident agent or attorney-in-fact of the surety company. The surety company must be notified of such changes.



CITY OF CHEYENNE
PERFORMANCE AND PAYMENT
BOND FORM

KNOW ALL MEN BY THESE PRESENTS:

That

_____ (Name of Contractor)

_____ (Address of Contractor)

a _____, hereinafter called Principal,

and _____ hereinafter called Surety, are
(Name of Surety)

held and firmly bound unto the City of Cheyenne, Wyoming, Municipal Building, 2101 O'Neil Avenue, hereinafter called City, in the penal sum of:

_____ Dollars

(\$ _____), in lawful money of the United States, for the payment of which sum well and truly to be made, we bind ourselves, successors and assigns, jointly and severally, firmly by these presents.

THE CONDITION OF THIS OBLIGATION is such that Whereas, the Principal entered into a certain contract with the City, dated the _____ day of _____, _____, a copy of which is hereto attached and made a part hereof for the

NOW, THEREFORE, if the Principal shall well, truly and faithfully perform its duties, all the undertakings, covenants, terms and conditions, and agreements, of said contract during the original term thereof, and any extensions thereof which may be granted by the City, with or without notice to the Surety and during the two-year guarantee period, and if the Principal shall satisfy all the claims and demands incurred under such contact, and shall fully indemnify and save harmless the City from all costs and damages which the City may suffer by reason of failure to do so, and shall reimburse and repay the City all outlay and expense which the City may incur in making good any default, then this obligation shall be void; otherwise to remain in full force and effect.

PROVIDED, FURTHER, that the said Surety, for value received hereby stipulates and agrees that no change, extension of time, alteration or addition to the terms of the Contract or to work to be performed thereunder or the specifications accompanying the same shall in any wise affect its obligation on this bond, and it does hereby waive notice of any such change, extension of time, alteration or addition to the terms of this contract or to the work or to the specifications.

PROVIDED, FURTHER, that no final settlement between the City and the Contractor shall abridge the right of any beneficiary hereunder whose claim may be unsatisfied.

IN WITNESS WHEREOF, this instrument is executed in ___ counterparts, each one of which shall be deemed an original, this the ___ day of _____, _____.

(Witness)

(Principal) (Seal)
By _____

(Title)

(Address)

(Witness)

(Surety) (Seal)
By _____

(Attorney-in-fact)

(Address)

Countersigned by:

By _____
(Wyoming Resident Agent)

(Address)

NOTE: Date of Bond must be same date as date of Contract. If Contractor is a partnership, all partners must execute bond.

IMPORTANT: Surety companies executing bonds must hold a Certificate of Authority issued by the State of Wyoming Insurance Department.

PART 6 – GENERAL CONDITIONS

CITY OF CHEYENNE, WYOMING

1.00 PROJECT SITE

US 30, Greenway Pump Station Replacement.

2.00 NOTICES

Any notice, correspondence, or billing required by the terms of this Agreement shall be delivered by hand or mail, prepaid, to the address of the respective party representative(s) named below:

CITY: Wes Bay
Engineering
2101 O’Neil Ave.
Cheyenne, WY 82001
Ph: 307-638-4315

3.00 DRUG-FREE WORKPLACE

In compliance with the Drug Free Work Place Act of November 1988, the City has established an “Alcohol and Controlled Substance Policy” that pertains to alcohol and drug usage by City employees. All independent contractors under contract with the City and their employees and subcontractors are required to comply with the provisions of this policy for drug and/or alcohol usage on City property or other sites occupied by the Contractor while performing the duties and responsibilities of the contract. It is the responsibility of the Contractor to become familiar with the requirements of this policy and to inform all subcontractors and employees of their obligation to comply and to ensure their compliance therewith. If the Contractor, the Contractor’s employees, or subcontractors are found in violation of this policy, the contract may be terminated. The Contractor is an independent Contractor and shall comply with the City’s Alcohol and Controlled Substance Policy and the provisions of this section.

4.00 NONDISCRIMINATION

The parties shall comply with the Civil Rights Act of 1964, the Wyoming Fair Employment Practices Act (Wyo. Stat. § 27-9-105 *et seq.*), the Americans With Disabilities Act (ADA (42 U.S.C. § 12101 *et seq.*)), the Age Discrimination Act of 1975, and any properly promulgated rules and regulations thereto and all parties to this Agreement assure that no person shall be excluded from participation in, denied the benefits of, or otherwise discriminated against in connection with the award and performance of this Agreement on the grounds of age, sex, race, creed, color, national origin, ancestry, religion, pregnancy, qualifying disability, sexual orientation, or gender identity. The parties further assure that they will include the language of this paragraph in all agreements associated or connected in any way with this Agreement and shall cause all existing Agreements to similarly include this clause therein.

5.00 CONTRACTS FOR PUBLIC IMPROVEMENTS

Wyo. Stat. § 15-1-113 is expressly incorporated herein by this reference as though fully set forth herein.

6.00 SAFETY PROGRAMS

The City, as mandated by Occupational Safety and Health Administration (“OSHA”), has in place many safety programs. All independent contractors, their employees, and their subcontractors, under contract with the City, must be familiar with and comply with any and all applicable OSHA standards, regulations, and provisions.

7.00 INDEPENDENT CONTRACTOR

At all times during the term of this Agreement, the Contractor shall be considered an independent contractor. Neither Contractor nor any one employed by it shall represent, act, purport to act, or be deemed to be the agent, representative, employee, or servant of the City.

8.00 CONFIDENTIALITY

To the extent allowed by law, the City and the Contractor shall treat as confidential and not disclose to others information (including technical information, experience, or data) regarding either party’s plans, programs, plants, processes, products, costs, equipment, operations, or customers which come within the knowledge of the parties, without in each instance securing the prior written consent of the other party, unless such disclosure is required by law or legal process. However, nothing shall prevent either Contractor or the City from disclosing to others, or using in any manner, information which either party can show (a) has been published or has become part of the public domain other than by acts of Contractor or the City; (b) has been furnished or made known to Contractor or the City by third parties without restrictions on its disclosure; or (c) was in either party’s possession prior to the disclosure thereof by the City or Contractor to each other. Contractor shall not be restricted in any way from releasing information in response to a subpoena, court order, or legal process, but shall notify City of the demand for information before Contractor responds to such demand. The City reserves the right to prohibit the release of said information as provided by law.

9.00 CONFLICT OF INTEREST

In entering this Agreement, the Contractor covenants that it presently has no interest, and shall not acquire any interest, direct, indirect, financial, or otherwise, which would conflict in any manner or degree with performance of the services hereunder. Contractor further covenants that in the performance of the Agreement, no subcontractor, or person having such an interest, shall be employed by the City. Contractor certifies that no one who has or will have any financial interest under this Agreement is an officer or employee of the City.

10.00 ACCEPTANCE NOT WAIVER

The City's approval of drawings, plans, specifications, reports, and incidental work, or materials furnished hereunder shall not in any way relieve Contractor from responsibility for the technical accuracy of the work. The City's approval or acceptance of, or payment for, any services shall not be construed to operate as a waiver of any of the City's rights under this Agreement or any of its legal rights under statute and common law arising out of the performance of this Agreement.

11.00 INSURANCE REQUIREMENTS

The Contractor shall file a Certificate of Insurance with the City verifying each type of insurance coverage listed below.

The Certificate of Insurance shall be submitted to and approved by the City before the Contractor begins to perform under this bid and the subsequent contract.

TYPE OF COVERAGE	MINIMUM POLICY REQUIREMENTS
Commercial General Liability <i>(Including Products and Completed Operations; Explosion, Collapse and Underground if applicable to the hazards of a specific project.)</i>	\$1,000,000 per Occurrence \$2,000,000 Aggregate
Business Automobile Liability	\$1,000,000 (Combined Single Limit)
Workers' Compensation <i>OR</i> Employer's Liability	Statutory \$500,000 Each Accident \$500,000 Each Disease-Policy Limit \$500,000 Disease/Each Employee

It is understood and agreed that these policies are primary and non-contributory. All policies required under this contract shall be in effect for the duration of the project and contract. The Contractor shall immediately notify in writing the City Risk Manager, City Clerk, and City Attorney of any fact, circumstance, or occurrence that has resulted in, or may result in, the cancellation or substantive change of any insurance coverage required by this contract, and failure to do so shall be construed to be a breach of this contract.

The Contractor shall name the City as an additional insured on the Contractor's insurance policies, except workers' compensation, and the Contractor shall provide a copy of the endorsements providing this coverage.

The City has the right to reject a certificate of insurance if the City determines that the Contractor's insurance company is widely regarded in the insurance industry as financially unstable. Any insurance company providing coverage under this contract shall have a minimum A.M. Best rating of A- (excellent).

The City has the right to review the insurance certificates of any or all Sub-Contractors used by the Contractor. Further, the City requires that the Sub-Contractors' insurance coverages be at least equivalent to that required of the Contractor.

The City has the right to increase the required minimum limit of liability on any contract project as warranted by an increase in hazard. Examples of increased hazard include, but are not limited to, handling of hazardous materials and activities involving large congregations of people.

The City shall have the right to consult with the Contractor's insurance agent for disclosure of relevant policy information, but the City's non-request or non-review such policies, endorsements, or certificates shall not affect the City's rights or Contractor's obligations hereunder. Disclosure of relevant policy information would specifically involve, but is not limited to, exclusions, deductibles, and claims in progress which could significantly reduce the annual aggregate limit.

12.00 INDEMNITY

In entering into the Agreement, the Contractor agrees to hold harmless, defend, and indemnify the City of Cheyenne, its officials, employees, agents, and authorized volunteers against any and all claims and costs, including attorneys' fees, arising during or resulting from the Contractor's performance of the contract. The Contractor shall carry insurance as set forth in these Contract Documents. The Contractor acknowledges its understanding of this paragraph and realizes it may have a financial responsibility to the City. The City does not waive any applicable defenses and expressly reserves the right to invoke governmental immunity pursuant to the Wyoming Governmental Claims Act, Wyo. Stat. § 1-39-101, *et seq.* for any claim arising out of performance of this agreement.

The Contractor expressly understands and agrees that although the City and the Engineer have the right under this Contract to observe and review the Contractor's work and operations, this right shall not relieve the Contractor from any of its covenants, obligations, or duties hereunder. The Contractor shall be responsible for and hold harmless the City, the Engineer, and their representatives from all suits, actions, or claims of any character, due to injuries or damages sustained by any person or property, in consequence of any neglect in performing the work, observing safety standards or regulations, through the use of unsafe or unacceptable practices or materials in the performance of the work, the Contractor's failure to comply with any law, ordinance or regulation or otherwise.

13.00 PROJECT RECORD DOCUMENTS

The Contractor shall maintain at the job site one copy of all Contract and project documents, each portion of which shall be clearly marked, "Project Record Copy". These documents, including drawings, specifications, addenda, approved shop drawings, change orders, field orders, other Contract Modifications, and other approved documents submitted by the Contractor in compliance with various sections of the Contract Documents, shall be maintained in good condition, available at all times for inspection by the City, and not used for construction purposes.

The Contractor shall mark up the most appropriate document to show significant changes made during construction progress, and significant detail not shown in the original Contract Documents. The information shall include, but shall not be limited to, location of underground utilities and appurtenances referenced to permanent surface improvements, and location of internal utilities and appurtenances concealed in building structures referenced to visible and accessible features of structures.

The Contractor shall keep the project record documents current and not permanently conceal any work until required information has been recorded. Upon completion of the project and prior to final acceptance, the Contractor shall submit the marked up set of project record documents to the Engineer for the City along with the “Contractor’s Certificate of Completion” found in the bidding documents. After the Engineer has inspected the work and has determined it to be substantially complete, the City will issue a “Certificate of Substantial Completion”, which will establish the date of commencement of the warranty period.

14.00 CONTRACT DOCUMENTS

The City will furnish to the Contractor, without charge, two (2) copies of the Contract Documents including technical specifications and drawings. Additional copies requested by the Contractor will be furnished at cost.

15.00 TIME FOR COMPLETION

The Contractor shall commence the work required under this contract at the time stipulated by the City in the Notice to Proceed. The Contractor shall complete the work by **June 30, 2022**. Time will not be counted when the project is officially suspended by the City due to acts of God, winter shutdown, and City-originated suspensions that are necessary through no fault of the Contractor. In the latter instance, if the City suspends the work for more than ninety (90) calendar days, the Contractor may apply for a price adjustment to compensate for reasonable expenses caused by the suspension. Any application for price adjustment or Contract Time extension will be submitted to the Governing Body of the City for its consideration in the form of a Contract Modification. It will be the responsibility of the Contractor to provide sufficient documentation to substantiate any claim.

16.00 JOB OFFICES AND STAGING AREA

The Contractor and Sub-Contractor(s) may maintain office and storage facilities on the site which are necessary to properly conduct the work. These facilities’ locations shall not cause any interference to any work performed on the site. The Contractor shall consult with the City regarding the locations. Upon completion of the improvements, or as directed by the City, the Contractor shall remove all such temporary structures and facilities from the site. The Contractor shall leave the site of the work in the condition required by the Contract.

On-site toilet facilities for employees of Contractors and Sub-Contractor(s) shall be provided and maintained in a sanitary condition. The Contractor shall remove all trace of these facilities prior to completion of the project.

17.00 THE USE OF CITY OWNED REFUSE CONTAINERS

All City contracts shall require all Contractors to use City-provided Sanitation services if available.

18.00 REFERENCE POINTS

Project survey points are provided by the City one time only, unless otherwise noted by the City in the appropriate project manual.

The Contractor shall make all surveys that will be necessary for the proper construction. The Contractor shall preserve all property pins and control points. If any of these are destroyed or disturbed due to the Contractor's construction activities or negligence, the Contractor will be charged at the Engineer's established hourly crew rate for replacing them, with payment for this extra work to be made directly to the Engineer by deduction from the monthly periodic estimate payments to the Contractor. The Contractor shall also be responsible for any mistakes or damage resulting from the unnecessary loss or disturbances of control points.

19.00 SEQUENCE OF WORK

The Contractor shall make every effort to complete the work in a manner and fashion that minimizes roadway closures and inconveniences to the traveling public and adjacent property owners. Once barricades are placed in the right-of-way, the Contractor shall show progress of work during normal Working Days and hours. If no progress of work is recorded for twenty-four (24) hours and no concrete is waiting for strength, the Contractor shall remove barricades, re-open the right-of-way, and provide a safe travel way for the public. If the Contractor does not re-open the right-of-way or show progress of work within twenty-four (24) hours, the City shall use any and all means necessary to re-open the area at the Contractor's expense. The Contract Documents are compiled to support the efficient operations of the Contractor and are not intended to supplant the Contractor's responsibility of superintendence. Special consideration regarding schedules or work sequences necessary or anticipated during the course of the project will be identified in the Special Provisions.

20.00 GENERAL TRAFFIC REQUIREMENTS

The Contractor shall provide adequate signs, barricades, lights, and flaggers, and take all necessary precautions to prevent accident or injury and to minimize inconvenience to the public during the progress of the work.

All traffic control or other protective devices shall be installed and maintained in accordance with the Uniform Manual of Traffic Control Devices or in conformance with the applicable requirements of the authority having jurisdiction in such matters. The Contractor shall provide an American Traffic Safety Services Association ("ATSSA")

certified work site supervisor to supervise all traffic control operations if the City deems necessary.

Material stored on or adjacent to public streets shall not obstruct or inconvenience the traveling public.

Streets, driveways, or other access points shall not be closed without the prior consent of the City, Engineer, and proper governmental authorities. Fire hydrants on or near the site of the work shall be accessible at all times. The Contractor shall notify affected property owners, the City and the Engineer at least 48 hours in advance of any proposed closure for construction operations including any work to be done by utility companies.

The Contractor shall submit a traffic control diagram to the City for approval before work begins. The diagram shall indicate location and type of signs, cones, flashers, flagging, reflective barricades, and all other devices deemed necessary for the proper protection of the work area.

21.00 EXISTING ROADWAYS AND OTHER PROPERTY

The Contractor shall take all necessary precautions to protect adjacent roadways, properties, improvements, and underground facilities affected by the Contractor's operations, regardless of the facilities' ownership.

Any existing improvements or facilities damaged by the Contractor's operations in the performance of the work under this Agreement shall be repaired or replaced by and at the expense of the Contractor to the satisfaction of the City.

The Contractor shall be responsible for the preservation and maintenance of all existing roadways affected but not directly disturbed by the work. The Contractor shall repair, replace, or clean any roadway indirectly affected by his or her operations during the course of the project. Such work shall be accomplished by and at the expense of the Contractor without reimbursement by the City.

22.00 FINAL CLEANUP

The Contractor shall clean all sidewalks, streets and other areas affected by construction and ensure removal of all loose surface materials. All piles of excess excavation, rocks, rubbish, or other debris shall be cleaned up and disposed of. Damage to any areas by the Contractor will be repaired or replaced by the Contractor at no expense to the City. No extra compensation will be allowed for final cleaning of the site, but the cost thereof shall be included in the unit price bid for other items in the Proposal. If work is suspended for any reason, the Contractor will be required at the Contractor's expense, prior to shut down, to provide for the public's safety and use as directed by the City or Engineer.

23.00 ENGINEER OR INSPECTOR OVERTIME AND USE OF CITY RESOURCES:

Inspection work required beyond normal working hours by any Engineer or Inspector having authority on the project must have the City's written approval twenty-four (24) hours in advance of scheduled work. In emergency situations, verbal approval may be

given followed by written approval on the next working day. In an emergency situation, verbal approval will suffice until the next working day at which time written approval will be obtained.

The City of Cheyenne Board of Public Utilities (“BOPU”) requires that requests for services on the weekend be made not later than 4:30 p.m. on the Thursday prior to need so that appropriate personnel arrangements can be made.

All costs for overtime inspection or professional services associated with the work will be paid for by the Contractor.

No City services, equipment, or personnel will be provided for this project unless specifically defined and stated in the bidding or contract documents, nor will any be provided free of charge unless expressly stated in these documents.

24.00 FORCE ACCOUNT, EXTRA WORK, AND WORK CHANGES

When the Contractor is required to do work or services under the force account or extra work, the cost for said work will be calculated using the provisions of the Wyoming Department of Transportation system for determining costs for equipment, operators and labor involved. Any extra work, additions, deletions or revisions in the work will be authorized by written Contract Modification or change orders. The Engineer may authorize minor changes or alterations in the work not involving extra cost and not inconsistent with the overall intent of the Contract Documents in the form of a Field Order.

25.00 CONTRACT MODIFICATIONS

- a. General: Contract Modifications are used to increase or decrease the total Contract Price, to alter the Contract Time, or to alter any other contract agreement provision. Each Contract Modification must be in writing, approved by the City’s Governing Body, and executed by the Mayor and Contractor.
- b. A Contract Modification does not invalidate the contract or release the surety. If the parties agree to a Contract Modification, the Contractor shall perform the work in the manner required by the contract as modified, except that the Contractor shall not perform any work which is subject to the Contract Modification, until such time as the City Engineer authorizes the Contractor to proceed. The City will initiate a request to modify the Contract by submitting the proposed Contract Modification to the Contractor for review and approval.

The City Engineer or agent thereof, *e.g.*, a project manager, may issue a Field Order to authorize the work to be paid for under the Force Account bid item or to adjust existing bid item quantities without increasing the total Contract Price. *See* Section 24.00. The Contractor may not begin work under any Contract Modification until the City Engineer has authorized the Contractor to proceed.

The Contractor shall use a Request for Adjustment form to request an adjustment of the Contract Time or Contract Price. The City shall have no obligation to process oral requests for modification of the Contract Time or Contract Price, and no City official shall have the

authority to approve oral modification requests. Proposed adjustments may be based upon extra work necessitated by an emergency, a change of conditions, or the City Engineer's interpretation of the contract requirements. Requests for Adjustments shall not be valid unless the Contractor has filed the request with the Engineer within:

1. Two (2) Working Days after the occurrence of the emergency or the discovery of any change in conditions which necessitates Additional Work; or
2. Five (5) Working Days after the effective date of a Work Directive.

The City will pay for adjustments and modifications based on contract unit bid prices. If the Contractor's cost of production or the character of the work is materially changed, the City may adjust the contract as specified in this section or seek a Contract Modification. The City will not pay for loss of anticipated profits resulting from adjustments or modifications, unless so specified in the adjustment or modification.

Differing Site Conditions: Before the conditions are disturbed or the affected work is performed or continued, the Contractor shall notify the City in writing if either of the following is encountered: (1) latent physical conditions that differ materially from those indicated in the contract; or (2) unusual physical conditions that differ materially from those ordinarily encountered and generally recognized as inherent in the work provided for in the contract. The City will not grant or consider Contract Modifications based on differing site conditions if the Contractor does not timely notify the City within two (2) Working Days after discovering latent or unusual physical conditions.

Significant Changes in the Character of Work: The Contract Unit Price of each bid item in the proposal shall include the *pro rata* share of overhead and profit so that the sum of the products obtained by multiplying the quantity shown for each item by the unit price bid represents the total bid. The City may alter the contract quantities, the Work, or both as necessary to complete the project, subject to the requirement that modifications to the Contract Price may be necessary in the event the alterations significantly change the character of the work. If alterations do not significantly change the character of the work specified in the contract, the City will pay for the altered work at contract unit prices and additional mark-ups for overhead and profit are not allowed.

Either of the following constitutes a "significant change" (1) when the character of the work, as altered, differs materially in kind or nature from that specified in the contract; or (2) in accordance with the relevant section in the Instruction to Bidders, when the net monetary value of all such additive and subtractive changes in quantities of such items increases or decreases the original total Contract Price by more than twenty percent (20%).

Extra and Force Account Work: When necessary or desirable to complete the project, the City may direct the Contractor to perform unforeseen work for which there is no pay item or unit price in the contract. The City shall seek a Contract Modification in the event the City's direction to perform unforeseen work results in an increase in the Contract Price, the alteration of the Contract Time or required any other modification of the Contract Agreement. The City Engineer may direct the Contractor to perform work under the Force Account item for minor changes or alterations in the work that do not increase the original

Contract Price. All Force Account Work shall be approved with a Field Order in accordance with the above procedures.

Extra work under the Force Account item shall be paid by one of the following methods: (1) Contract unit bid prices that are representative of the work being performed, as specified in item Significant Changes in the Character of Work; and (2) Negotiated unit bid prices for items where the Contractor's cost of production or the character of the work is materially changed. The negotiated unit bid prices shall include the *pro rata* share of overhead and profit. Overhead and profit mark-up on Sub-Contractor unit bid prices shall be limited to five percent (5%); (3) lump sum, as stipulated in the order authorizing the work. Documentation for lump sum pricing shall be provided to a degree sufficient for the City Engineer to review for acceptability. Overhead and profit shall be limited to five percent (5%) on Sub-Contractor work and fifteen percent (15%) on work by Contractor's own forces; and (4) Time and material basis utilizing approved materials, equipment, and labor costs calculated under the provisions of the latest edition of the Wyoming Department of Transportation Specifications Subsection 109.4.4.

26.00 PARTIAL USE OF SITE IMPROVEMENTS

The City may give notice to the Contractor and place in use those sections of the improvements which have been completed, inspected, and can be accepted as complying with the Contract Documents if, in its opinion, each section is reasonably safe, fit and convenient for the use and accommodation for which it was intended, provided:

The use of such sections of the improvements shall in no way impede the completion of the remainder of the work by the Contractor;

The Contractor will not be responsible for any damages or maintenance costs due directly to the use of such sections;

The use of such sections shall in no way relieve the Contractor of liability arising from having used defective materials or to poor workmanship.

Any guarantee period shall not commence until the date of the final acceptance of all work which the Contractor is required to construct under this contract.

27.00 TWO YEAR WARRANTY PERIOD

If after the approval of final payment and prior to the expiration of two (2) years after the date of Substantial Completion or such longer period as may be prescribed by law or by the terms of any applicable special guarantee, the Contractor shall promptly, without cost to the City and in accordance with the City's written instructions, either correct such defective work or, if it has been rejected by the City, remove it from the site and replace it with non-defective work within thirty (30) calendar days of written notification by the City. If the Contractor does not promptly comply with the terms of such instruction, the City may have the defective work corrected or the rejected work removed and replaced, and all costs incurred therefore, including compensation for additional professional services, shall be paid by the Contractor and its sureties. The remedies provided in this section are in

addition to all other remedies available to the City under applicable law and shall not be construed as exclusive of any other legal right or remedy available to the City.

28.00 COMPLETION AND WARRANTY

The following replaces the City of Cheyenne & Board of Public Utilities Standard Construction Specifications and Standard Drawings, 2014 Edition, Section 01054.1.10-Acceptance of the Standard Specification.

Substantial Completion. Shall be defined as when the project can be safely and effectively used by the public for its intended use, without further delays, disruptions, or other impediments and only clean up and work of a minor nature remains to be finished, as agreed to by the City Engineer or as otherwise specified. After written notice from the Contractor of Substantial Completion, the Engineer and the City shall make a determination of acceptance of substantial completion. If in agreement, the City will issue written notice of Substantial Completion at which date the contract time will stop. The Engineer will then make an inspection of the project and develop a punch list of items to be completed. The Contractor will have thirty (30) calendar days to complete all punch list items, with the exception of seasonal work item, which will be as agreed by the Engineer and the City. Liquidated damages may be assessed by the City, in accordance with Section 29.00, for every day that expires after the allotted time for the completion of the punch list.

Warranty. The specified date in the City's Notice of Substantial Completion issued to the Contractor shall be the effective date for the beginning of the two-year warranty period.

Final Completion. After completion of the punch list, the Contractor shall issue the Contractor's Certificate of Completion along with the marked-up Project Record Drawings in accordance with Project Documents. At that time the Engineer and the City shall inspect and if all construction provided for and contemplated by the contract is found to be complete to their satisfaction, this inspection shall constitute the final inspection and the Engineer shall make the final acceptance. The Contractor shall be notified in writing as to the date of the Final Completion.

Prior to the end of the Warranty Period, the City shall inspect the Project for defects in the workmanship or material. A written deficiency list shall be developed and provided to the Contractor. Normal wear and tear shall not be considered a deficiency. The Contractor shall promptly, without cost to the City and in accordance with the City's written instructions, either correct such defective work or, if it has been rejected by the City, remove it from the site and replace it with non-defective work within thirty (30) calendar days of written notification by the City.

29.00 LIQUIDATED DAMAGES

For each calendar day that any work shall remain uncompleted after the contract time specified for the completion of the work provided for in the contract, the following liquidated damages charges will be deducted from any monies due the Contractor:

ORIGINAL CONTRACT AMOUNT		LIQUIDATED DAMAGE CHARGE
From (\$)	To and including (\$)	Charge per calendar day (\$)
0.00	25,000.00	250.00
25,000.01	50,000.00	500.00
50,000.01	100,000.00	1000.00
100,000.01	500,000.00	1500.00
500,000.01	1,000,000.00	2000.00
1,000,000.01	1,500,000.00	3000.00
1,500,000.01	and greater	3500.00

Permitting the Contractor to continue and finish the work or any part of it after the time fixed for its completion, or after the use of additional contract time, will in no way constitute a waiver on the part of the City to any of its rights under the contract.

Unless otherwise provided in the contract, liquidated damage charges will be calculated in accordance with the table. All time in excess of the required Contract Time will be calculated on a calendar day basis.

30.00 GOVERNMENTAL IMMUNITY

The City and its officials and employees do not waive governmental immunity by entering into this Agreement and specifically retain all immunities and defenses available to them as Governmental Entities pursuant to Wyo. Stat. § 1-39-101, *et seq.*, and all other applicable laws. Further, the City fully retains all immunities and defenses provided by law with regard to any action, whether in tort, contract, or any other theory of law, based on this Agreement. The City does waive its governmental immunities solely for the enforcement of the terms and conditions of this Agreement.

31.00 GOVERNING LAW, JURISDICTION, AND VENUE

The construction, interpretation, and enforcement of this Agreement shall be governed by the laws of the State of Wyoming. The courts of the State of Wyoming shall have jurisdiction over any action arising out of this Agreement and over the parties, and the venue shall be the First Judicial District, Laramie County, Wyoming.

32.00 COMPLIANCE WITH LAWS

This Agreement shall be governed in all respects by the laws of the State of Wyoming. The parties hereto shall comply with all applicable federal, state, and local laws, rules, and regulations in the performance of this contract. The identified laws or regulations are included in this Agreement as mandated by statute or for the convenience of the Contractor. The Contractor’s attention is directed to the fact that all applicable federal and state laws, municipal ordinances, and the rules and regulations of all authorities having jurisdiction over design and construction of the project shall apply to the Agreement throughout, and they are deemed incorporated herein. Other laws and regulations apply which are not included herein, and are within the Contractor’s duty and responsibility for compliance therewith.

33.00 DEFAULT

Each and every term and condition herein shall be deemed a material element of this Agreement. In the event either party shall fail or refuse to perform according to the terms of this Agreement, such party may be declared in default.

34.00 REMEDIES

In the event a party declares the other party in default hereof, said party declaring default shall notify the defaulting party in writing, and such defaulting party shall be allowed a period of fifteen (15) calendar days to cure said default. In the event that the default remains uncorrected, the party not in default may elect to: (a) terminate this Agreement and seek damages; (b) treat this Agreement as continuing and require specific performance; or (c) avail itself of any other remedy at law or equity.

In the event Contractor fails to strictly perform in accordance with this Agreement, the City may elect to make good such deficiencies and charge Contractor therefore.

35.00 TERMINATION

The City may, by written notice to Contractor, terminate this Agreement, in whole or in part, by giving Contractor fifteen (15) calendar days written notice. Upon receipt of such notice, Contractor shall discontinue all services affected (unless the notice directs otherwise), and deliver to the City representative within five (5) calendar days all documents belonging to the City, including but not limited to, data, drawings, specifications, reports, estimates, and summaries accumulated by the Contractor in the performance of this Agreement, whether completed or in progress. In the event of termination, the City shall pay Contractor for all work accepted as of the date of termination.

36.00 WAIVER

The waiver by either party of any term, condition, or covenant, or breach of any term, condition, or covenant, shall not constitute a waiver of any other term, condition, or covenant, or breach thereof.

37.00 SEVERABILITY

If any provision, section, subsection, sentence, clause, or phrase of this Agreement is invalidated by any court of competent jurisdiction, such holding shall not affect the validity of the remainder of the Agreement, which shall continue in full force and affect.

38.00 SUCCESSORS AND ASSIGNS

All the terms, conditions, and provisions herein shall inure to the benefit of and be binding upon the parties hereto and their respective successors and assigns.

39.00 ASSIGNMENT

Neither party shall assign this Agreement without prior written consent of the other party. Any delegation or assignment shall not operate to relieve either party of its responsibilities hereunder.

40.00 THIRD PARTY RIGHTS

The parties do not intend to create in any other individual or entity the status of third party beneficiary, and this Agreement shall not be construed so as to create such status. The rights, duties and obligations contained in this Agreement shall operate only between the parties to this Agreement, and shall inure solely to the benefit of the parties to this Agreement. The parties to this Agreement intend and expressly agree that only the parties signatory to this Agreement shall have any legal or equitable right to seek to enforce this Agreement, to seek any remedy arising out of a party's performance or failure to perform any term or condition of this Agreement. This paragraph is not intended nor shall it be construed to waive all the parties' immunities.

41.00 FORCE MAJEURE

The performance of the Agreement by either party shall be subject to force majeure including, but not limited to, acts of God, fire, flood, natural disaster, war or threat of war, acts or threats of terrorism, civil disorder, unauthorized strikes, governmental regulation or advisory, recognized health threats as determined by the World Health Organization, the Centers for Disease Control, or local government authority or health agencies (including, but not limited to, the health threats of COVID-19, H1N1, or similar infectious diseases), curtailment of transportation facilities, or other similar occurrence beyond the control of the parties, where any of those factors, circumstances, situations, or conditions or similar ones prevent, dissuade, or unreasonably delay the performance required by this Agreement. The Agreement may be cancelled by either party, without liability, damages, fees, or penalty, and any unused deposits or amounts paid shall be refunded, for any one or more of the above reasons, by written notice to the other party.

PART 7 - SPECIFICATIONS

CITY OF CHEYENNE, WYOMING

THE STANDARD SPECIFICATIONS GOVERNING THIS PROJECT SHALL BE THE “CITY OF CHEYENNE/BOARD OF PUBLIC UTILITIES CONSTRUCTION SPECIFICATIONS AND STANDARD DRAWINGS, 2014” WITH APPROVED AMENDMENTS ISSUED BY THE CITY ENGINEER AT THE TIME OF THIS CONTRACT.

IT IS THE CONTRACTOR’S RESPONSIBILITY TO KEEP CURRENT ON THESE AMENDMENTS. COPIES OF THESE AMENDMENTS ARE AVAILABLE ON THE CITY’S WEBSITE AT <http://www.cheyennecity.org>.

SPECIAL PROVISIONS

THE SPECIAL PROVISIONS WILL ADD TO OR REVISE CERTAIN SECTIONS OF THE “CITY OF CHEYENNE/BOARD OF PUBLIC UTILITIES CONSTRUCTION SPECIFICATIONS AND STANDARD DRAWINGS, 2014”. REVISED PARAGRAPHS AND ADDITIONS WILL CORRESPOND TO THE STANDARD NUMERICAL AND TITLE DESIGNATIONS.

THE SPECIAL PROVISIONS MAY ALSO INCLUDE NEW SECTIONS OF SPECIFICATIONS NOT COVERED IN THE STANDARD SPECIFICATIONS AND WILL BE NUMBERED STARTING FROM SECTION 04000.

US 30 Greenway Pump Station Replacement

TENTATIVE PROJECT TIMELINE

Legal Advertisement:	September 22 & 29, 2021
Pre-Bid Meeting:	September 30, 2021
Question Submission Date:	October 6, 2021
Addendum Response Deadline:	October 8, 2021
Bid Opening:	October 15, 2021
City Council 1st Reading:	October 25, 2021
Finance Committee:	November 1, 2021
City Council Final Approval:	November 8, 2021
Contract Signature Processing:	November 9-12, 2021
Notice to Proceed (Estimated):	November 15, 2021
Final Completion:	June 30, 2022

Section 01041 Project Coordination:

PART 4 METHOD OF MEASUREMENT AND BASIS OF PAYMENT

Add the following as Part 4, Method of Measurement and Basis of Payment:

4.01 METHOD OF MEASUREMENT

- A. No separate measurement shall be allowed for other items not specifically defined under this section or shown on the contract Bid Schedule.
- B. **Mobilization** will be measured as the complete series of setups required to complete the contract.
- C. Any required insurance, bid bonds, performance and payment bonds, warranty bonds, permit fees and other fees required by the scope of work included in the contract documents shall be measured under **Bonds, Insurance, and Fees** and be lump sum.

4.02 BASIS OF PAYMENT

- A. **Mobilization** will be paid for at the contract Lump Sum price. No adjustment to the contract price for Mobilization will be allowed unless authorized by the ENGINEER. Payment shall be made with a monthly estimate based on the percentage of the original contract amount earned in accordance with the following:
 - i. At the first request, up to 50% of the bid amount for Mobilization will be paid.
 - ii. When 50% of the original contract amount in a given construction period is earned, a further 30% of the amount of the bid for this item will be paid.
 - iii. At the final pay request, the remainder of the bid amount for Mobilization will be paid.
- B. Payment for **Bonds, Insurance, and Fees** will be paid for at the contract Lump Sum price. No adjustment to the contract price for these items will be allowed unless authorized by the ENGINEER. Payment shall be in accordance with the following:
 - i. At the first request, up to 90% of the bid amount for Bonds, Insurance, & Fees will be paid.
- C. Full compensation for items not specifically separated for payment under this section or shown on the project Bid Schedule shall be considered as included in the prices paid for the various other contract items and no additional compensation shall be allowed.
- D. All items under this section are subject to a five percent (5%) retainage that will be withheld until final payment.

Section 04000 Remove and Replace Stormwater Pump Station

PART 4 METHOD OF MEASUREMENT BASIS OF PAYMENT

4.01 METHOD OF MEASUREMENT

- A. Measurement of work and materials associated with Remove and Replace Stormwater Pump Station, as designated on the contract design plans shall be measured as a single unit lump sum. Subsidiary items include, but not be exclusive to, include the Bill of Materials listed on the contract design plans, quality control testing, demolition, piping and appurtenances, backfill, resurfacing, reseeding, and restoration, etc. to complete the work prescribed. Any minor items of labor, or materials not specifically noted in this Special Provision, General Specifications, or prescribed with the Contract Design Plans which is necessary for the proper completion of the work described will be considered incidental and are to be included in the contract.

4.02 BASIS OF PAYMENT

- A. Payment for Remove and Replace Stormwater Pump Station shall be made at the contract lump sum price. Major materials as described by the Bill of Materials that are installed and operational on jobsite over 30 days may be considered for partial payment upon receipt of documentation for the materials (i.e. vendor invoice, bill of lading, sub-contractor invoicing etc.) at the discretion of ENGINEER and OWNER.
- B. Full compensation for items not specifically separated for payment under this section or shown on the project Bid Schedule shall be considered as included in the prices paid for the other various contract items and no additional compensation shall be allowed.

- C. Payment shall be made under:

<u>Pay Item</u>	<u>Pay Unit</u>
Remove and Replace Stormwater Pump Station	LS

- D. All items under this section are subject to a five percent (5%) retainage that will be withheld until final payment.

Section 04001 Relocation of Low Water Crossing

PART 4 METHOD OF MEASUREMENT BASIS OF PAYMENT

4.02 METHOD OF MEASUREMENT

- A. Measurement of work and materials associated with Relocate Low Water Crossing, as designated on the contract design plans shall be measured as a single unit lump sum. Subsidiary items include, but not be exclusive to, include the Bill of Materials listed on the contract design plans, quality control testing, demolition, restoration, piping and appurtenances, backfill, resurfacing, reseeding and restoration, etc. to complete the work prescribed. Any minor items of labor, or materials not specifically noted in this Special Provision, General Specifications, or prescribed with the Contract Design Plans which is necessary for the proper completion of the work described will be considered incidental and are to be included in the contract.

4.02 BASIS OF PAYMENT

- A. Payment for Relocate Low Water Crossing shall be made at the contract lump sum price. Major materials as described by the Bill of Materials that are installed and operational on jobsite over 30 days may be considered for partial payment upon receipt of documentation for the materials (i.e., vendor invoice, bill of lading, sub-contractor invoicing etc.) at the discretion of ENGINEER and OWNER.
- B. Full compensation for items not specifically separated for payment under this section or shown on the project Bid Schedule shall be considered as included in the prices paid for the other various contract items and no additional compensation shall be allowed.
- C. Payment shall be made under:

<u>Pay Item</u>	<u>Pay Unit</u>
Relocate Low Water Crossing	LS

- D. All items under this section are subject to a five percent (5%) retainage that will be withheld until final payment.

I:\Projects\11-15-20\Drawings\Drawings\Projects\2020\202019 - US 30 Greenway Pump Station\Drawings\2020\202019 - US 30 Greenway Pump Station\04 Drawings\0400 Construction\Sheet\04_Letting Conditions and Demolition\Plan.dwg | 8/2/2021 11:53 AM

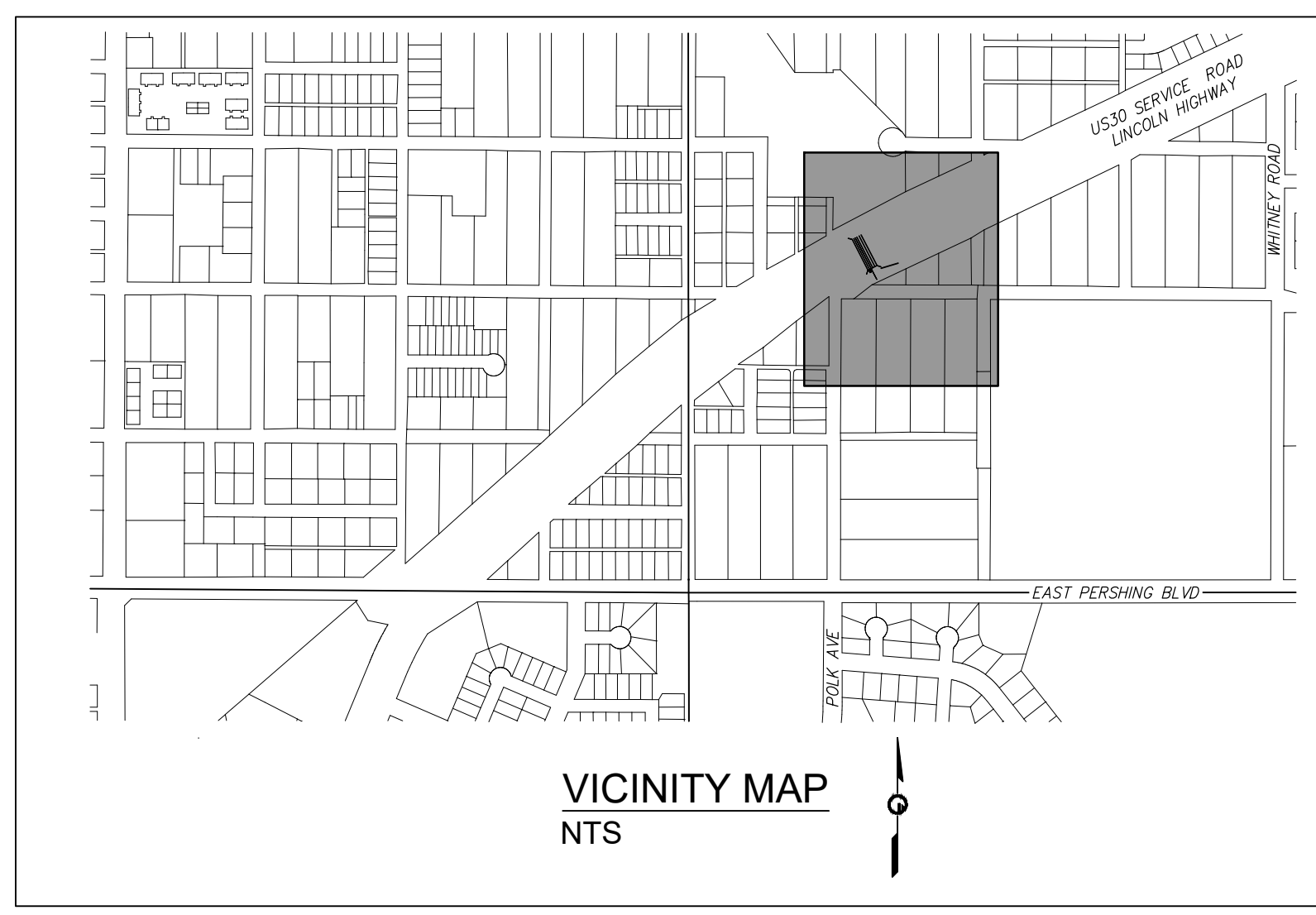
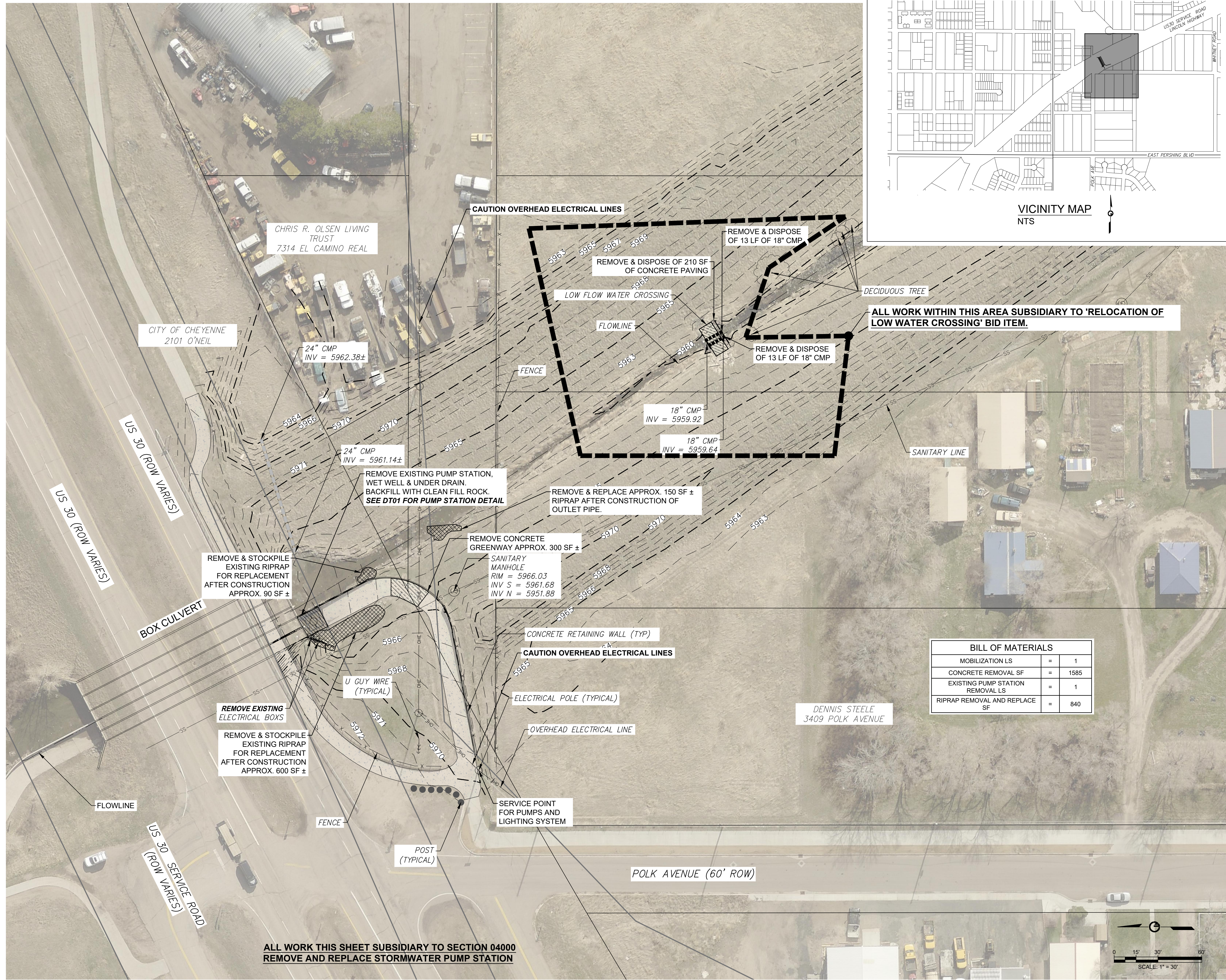

LEGEND

MAPPING / SITE

- PROPERTY BOUNDARY
- FLOWLINE
- FENCE
- EXISTING CONTOURS
- PUMP STATION

UTILITIES

- SANITARY LINE
- SANITARY MANHOLE
- STORM DRAIN PIPE
- OVERHEAD ELECTRIC
- ELECTRICAL POLE
- ELECTRICAL BOX
- GUY WIRE

DEMOLITION

- REMOVE EXISTING SITE
- REMOVE EXISTING RIPRAP
- REMOVE EXISTING CONCRETE

NOTES

- EXISTING UNDERGROUND AND OVERHEAD PUBLIC AND PRIVATE UTILITIES AS SHOWN ARE INDICATED ACCORDING TO THE BEST INFORMATION AVAILABLE TO THE ENGINEER.
- THE CONTRACTOR SHALL PROTECT ALL EXISTING FEATURES THAT ARE NOT TO BE REMOVED ADJACENT TO THE CONSTRUCTION AREA INCLUDING, BUT NOT LIMITED TO, PAVEMENT, PRIVATE FENCES, ABOVE GROUND OR UNDERGROUND UTILITIES, STRUCTURES, AND UNDERGROUND FOUNDATIONS. THE CONTRACTOR SHALL BE RESPONSIBLE FOR ANY DAMAGE THAT SHOULD OCCUR TO ANY ON-SITE, OFF-SITE, PUBLIC OR PRIVATE FACILITY OR FEATURE AS A RESULT OF THE CONSTRUCTION PROCESS FOR THIS PROJECT.
- GREENWAY SHALL BE REMOVED TO THE NEAREST JOINT & SHALL BE REPLACED PER DETAIL ON SHEET DT03.
- PUMP & CONTROLS FROM EXISTING PUMP STATION SHALL BE SALVAGED & PROVIDED BACK TO CITY PARKS DEPARTMENT.
- CONTRACTOR SHALL COORDINATE ALL CONSTRUCTION ITEMS IMPACTING ADJACENT PROPERTIES WITH THE PROPERTY OWNERS PRIOR TO BEGINNING ANY CONSTRUCTION ACTIVITIES.

BILL OF MATERIALS		
MOBILIZATION LS	=	1
CONCRETE REMOVAL SF	=	1585
EXISTING PUMP STATION REMOVAL LS	=	1
RIPPRAP REMOVAL AND REPLACE SF	=	840

4025 Automation Way
Suite B2
Fort Collins, CO 80525
(970) 698-6046
CivilWorxeng.com

APPROVED

Aug. 20 2021
8:25:55 AM

Engineering, BOPU, Fire

US30 GREENWAY PUMP STATION

EXISTING CONDITIONS AND DEMOLITION

DATE SUBMITTED: 6/14/2021

PREPARED FOR: CITY OF CHEYENNE

SHEET NUMBER

EX01

2 OF 7 SHEETS

SCALE

VERTICAL: N/A

HORIZONTAL: 1" = 30'

JOB NUMBER

C20019

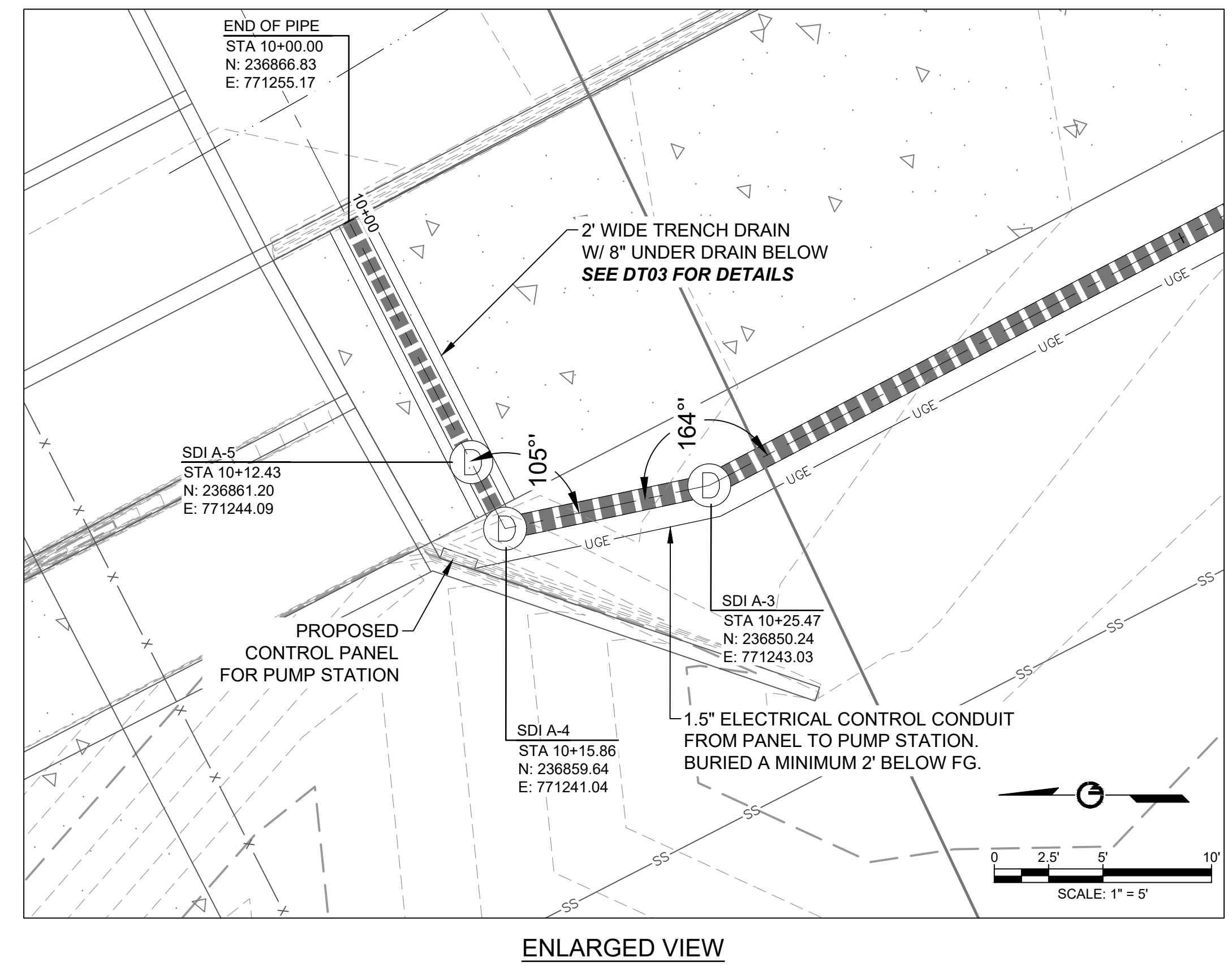
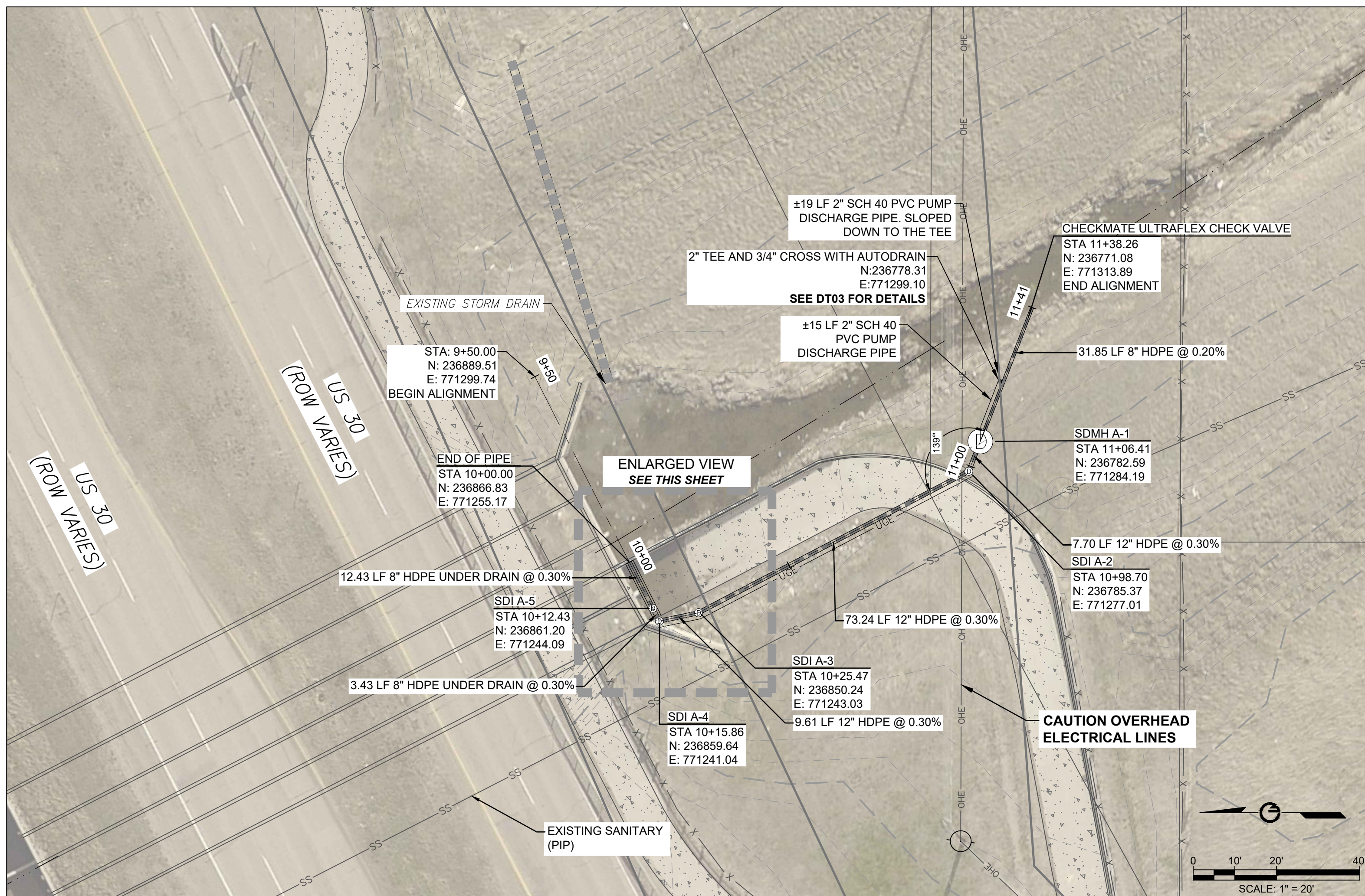

- ### LEGEND
- EXISTING MAPPING / SITE**
- PROPERTY BOUNDARY
 - FLOWLINE
 - FENCE
- PROPOSED UTILITIES**
- STORM DRAIN PIPE
 - STORM DRAIN MANHOLE & INLET
 - UNDERGROUND ELECTRICAL CONDUIT
- EXISTING UTILITIES**
- SANITARY LINE
 - SANITARY MANHOLE
 - STORM DRAIN PIPE
 - OVERHEAD ELECTRIC
 - ELECTRICAL POLE
 - ELECTRICAL BOX
 - GUY WIRE

- ### NOTES
- EXISTING UNDERGROUND AND OVERHEAD PUBLIC AND PRIVATE UTILITIES AS SHOWN ARE INDICATED ACCORDING TO THE BEST INFORMATION AVAILABLE TO THE ENGINEER.
 - ALL STORM SEWER CONSTRUCTION SHALL BE PER CITY OF CHEYENNE STANDARD CONSTRUCTION SPECIFICATIONS, LATEST EDITION.
 - ALL PIPE LENGTHS ARE FROM CENTER TO CENTER OF ADJACENT STRUCTURES UNLESS OTHERWISE NOTED.
 - STORM SEWER MAINS SHOWN ON THESE DRAWINGS AS HIGH-DENSITY POLYETHYLENE (HDPE) UNLESS OTHERWISE NOTED.
 - MAINTAIN 10' HORIZONTAL AND 18" VERTICAL MINIMUM SEPARATION BETWEEN ALL SANITARY SEWER & WATER MAINS & SERVICES.
 - STORM DRAIN PIPES ENTER AND EXIT AT 90° INTERVALS UNLESS OTHERWISE SHOWN.

4025 Automation Way
Suite B2
Fort Collins, CO 80525
(970) 698-6046
CivilWorxeng.com

NO.	DATE	BY	CHK	DESCRIPTION

APPROVED
Aug. 20 2021
8:25:55 AM
Engineering, BOPU, Fire

US30 GREENWAY PUMP STATION

STORM DRAIN PLAN AND PROFILE

DATE SUBMITTED: 6/14/2021
PREPARED FOR: CITY OF CHEYENNE

SHEET NUMBER
SD01
3 OF 7 SHEETS

SCALE
VERTICAL: 1" = 5'
HORIZONTAL: 1" = 20'

JOB NUMBER
C20019

ALL WORK THIS SHEET SUBSIDIARY TO BID ITEM REMOVE AND REPLACE STORMWATER PUMP STATION

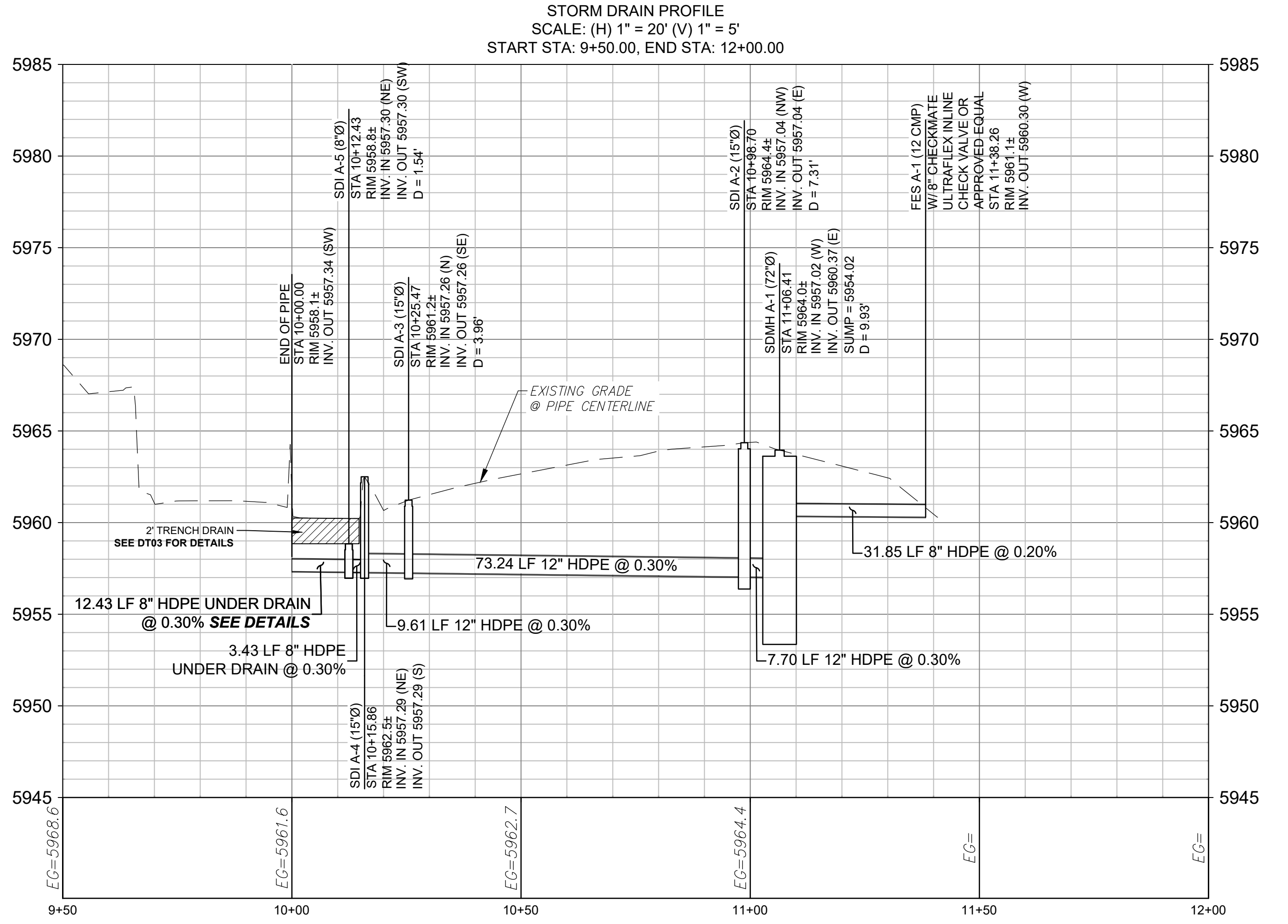

BILL OF MATERIALS

15" NYOPLAST INLET OR APPROVED EQUAL	=	3
8" DOME GRATE	=	1
72" STORM DRAIN MANHOLE	=	1
8" HDPE UNDER DRAIN STORM SEWER LF	=	15
8" HDPE STORM SEWER LF	=	32
12" HDPE STORM SEWER LF	=	128
2" SCHEDULE 40 PVC LF	=	43
PUMPS AND CONTROLS	=	1
8" CHECK VALVE	=	1
8" INLET	=	1
24" TRENCH DRAIN WITH GRATE LF	=	15
8" PERFORATED PIPE	=	15
AGGREGATE FOR DRAINS CF	=	68
ENGINEERING FABRIC SF	=	90
6" CONCRETE SIDEWALK SF	=	330
4" CRUSHED BASE TON	=	11

INLET SCHEDULE

INLET ID	TYPE
SDI A-1	15" NYOPLAST INLET WITH DROP IN GRATE*
SDI A-2	15" NYOPLAST INLET WITH DROP IN GRATE*
SDI A-3	15" NYOPLAST INLET WITH DROP IN GRATE*
SDI A-4	15" NYOPLAST INLET WITH DROP IN GRATE*
SDI A-5	8" NYOPLAST INLET WITH DOME GRATE

* OR APPROVED EQUAL
QUANTITIES ARE SHOWN FOR INFORMATION ONLY & SHOULD NOT BE USED FOR BIDDING WITHOUT VERIFICATION BY THE CONTRACTOR

I:\P\001011 | D:\CivilWorx\Dropbox\CivilWorx\Projects\2020\C20019 - US 30 Greenway Pump Station\04 Drawings\AutoCAD\Construction\Sheet\LF_Low Flow Crossing Detail.dwg | 8/2/2021 11:32 AM |

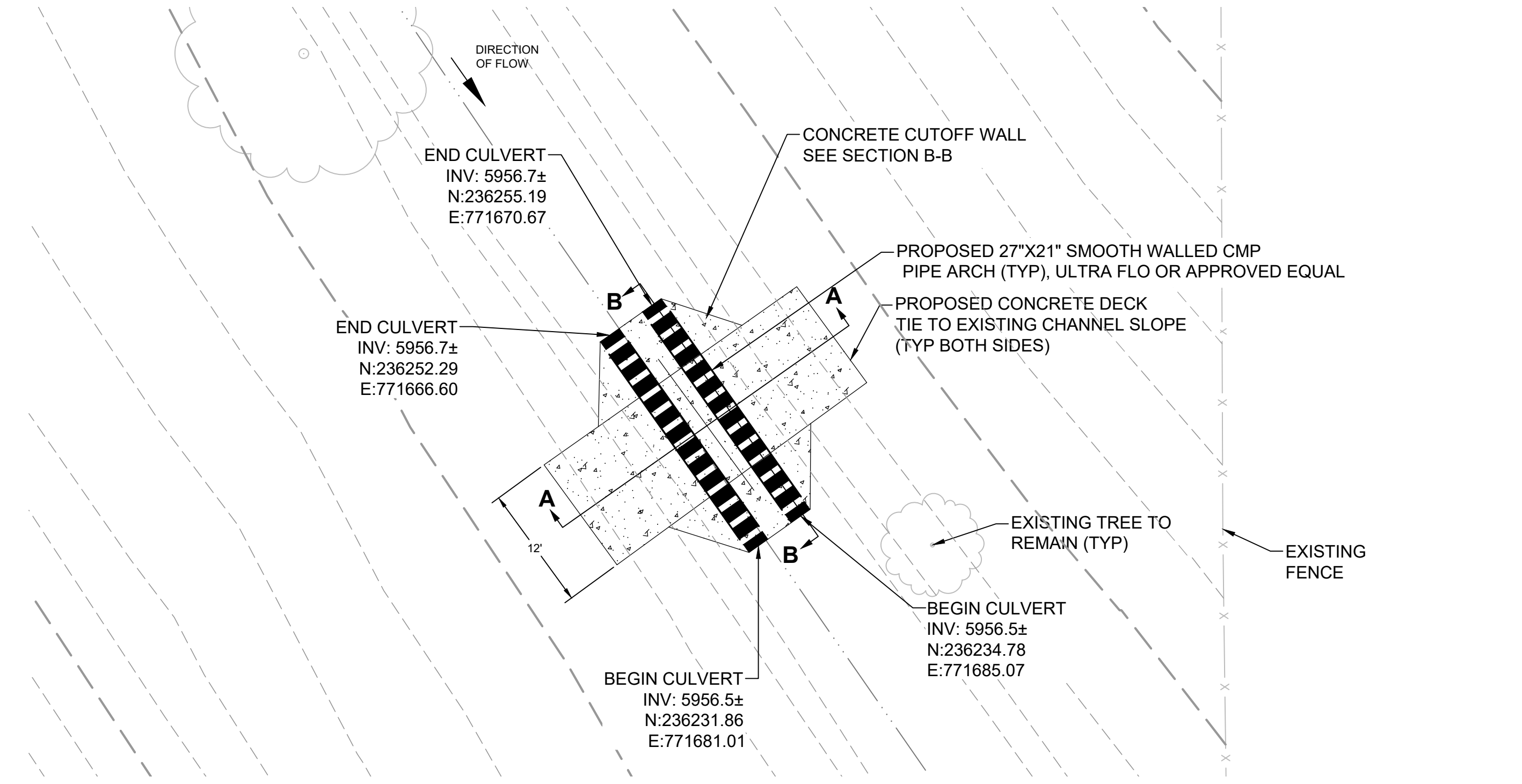

PLAN VIEW

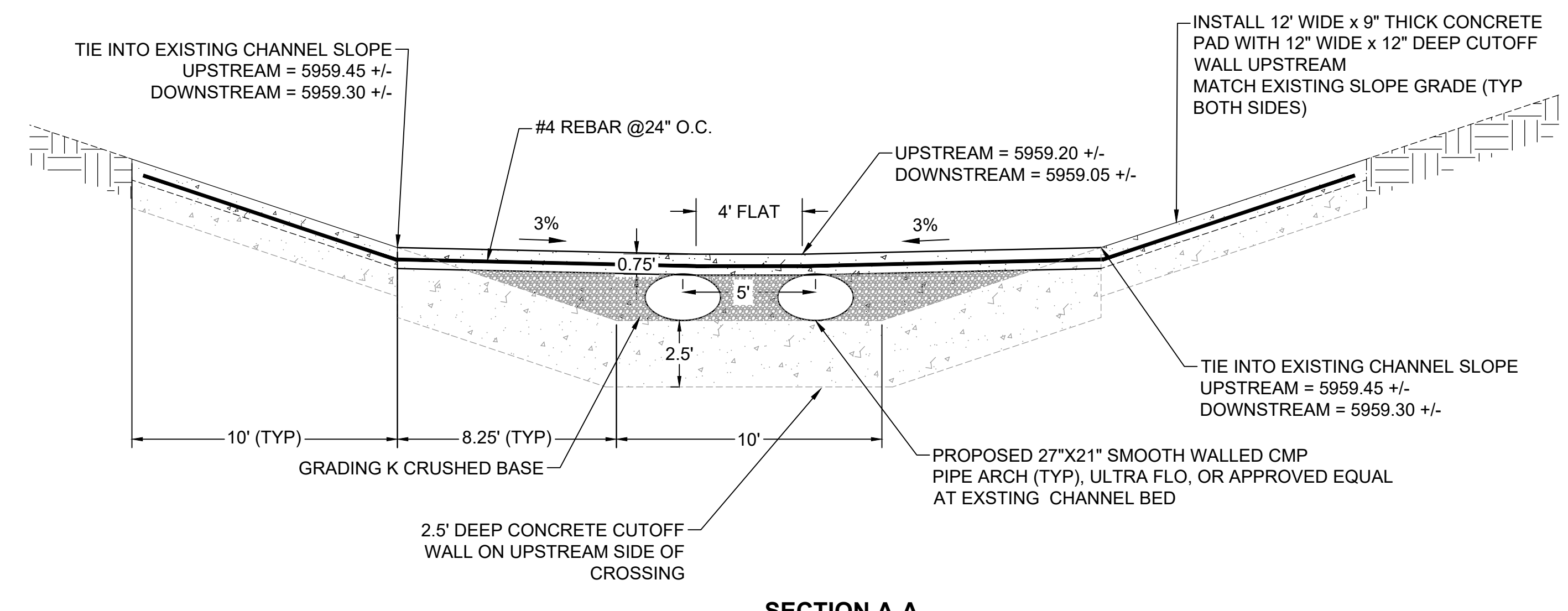

SECTION A-A

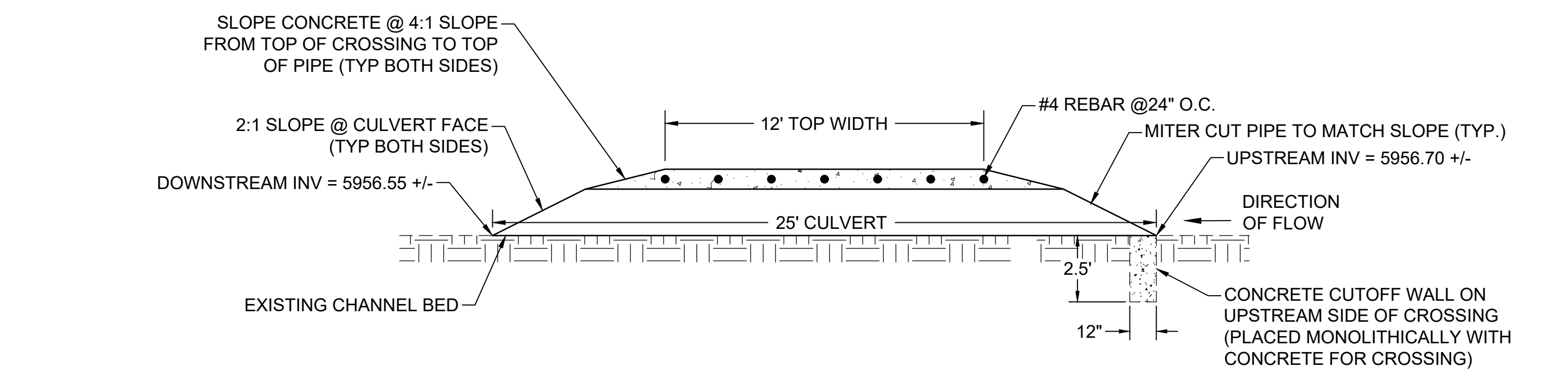

SECTION B-B

BILL OF MATERIALS		
REMOVE AND DISPOSE OF 18" CMP LF	=	26
STREAM RESTORATION	=	1
27"x21" ULTRA FLO PIPE ARCH OR APPROVED EQUAL (LF)	=	50
CITY MIX CONCRETE (CY)	=	32
GRADING K OR W CRUSHED BASE (CY)	=	25

- GENERAL CONSTRUCTION NOTES:**
- ALL REINFORCING STEEL SHALL BE EPOXY COATED AND PLACED WITH 3" COVER MINIMUM.
 - CONCRETE SHALL BE WYDOT CLASS B OR APPROVED EQUAL.
- ALL WORK THIS SHEET SUBSIDIARY BID ITEM
RELOCATION OF LOW WATER CROSSING**

4025 Automation Way
Suite B2
Fort Collins, CO 80525
(970) 698-6046
CivilWorxeng.com

REV.	DATE	BY	CHK	DESCRIPTION

The engineer preparing these plans will not be responsible for, or liable for, unauthorized changes to or uses of these plans. All changes to the plans must be in writing and must be approved by the preparer of these plans.

City of Cheyenne
APPROVED
Aug. 20 2021
8:25:55 AM
Engineering, BOPU, Fire

**US30 GREENWAY PUMP STATION
LOW FLOW CROSSING DETAIL**

DATE SUBMITTED: 6/14/2021
PREPARED FOR: CITY OF CHEYENNE

SHEET NUMBER
LF01
4 OF 7 SHEETS

SCALE
VERTICAL: N/A
HORIZONTAL: 1" = 60'

JOB NUMBER
C20019

0899CGD

APPROX. DRAIN AREA = 30.00 SQ IN
APPROX. WEIGHT = 4.54 LBS

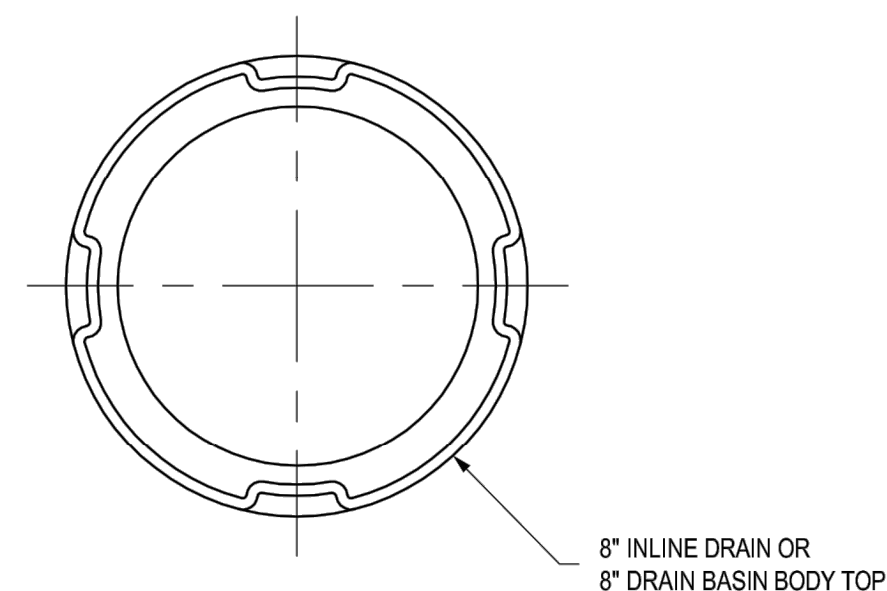
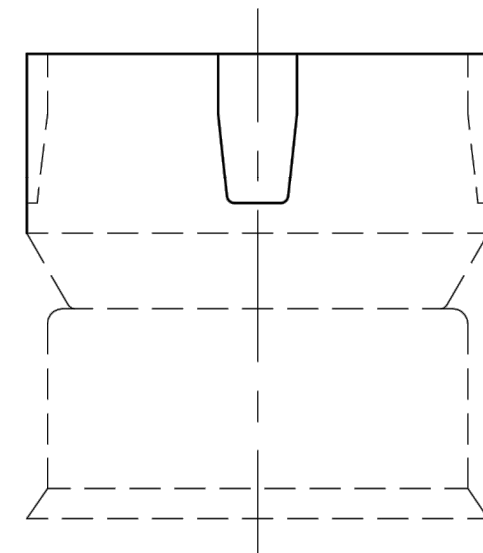
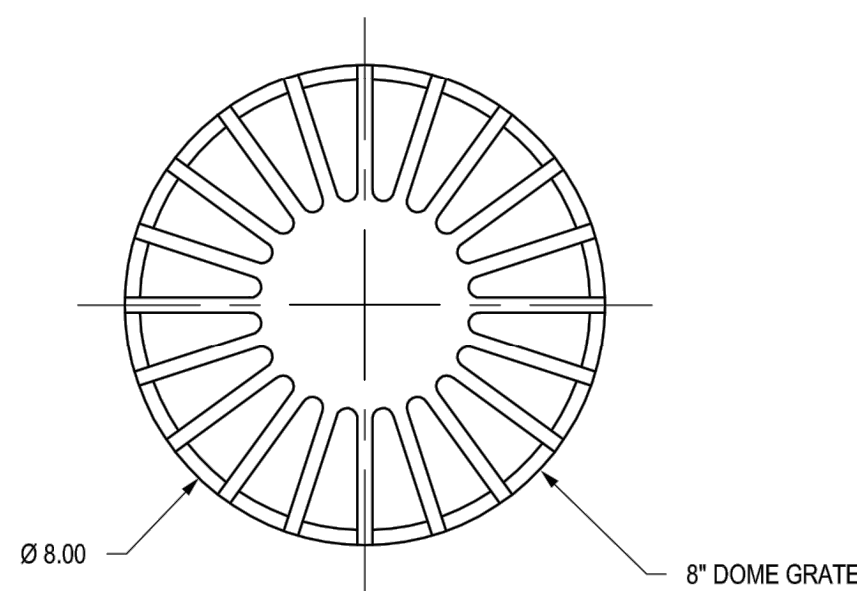
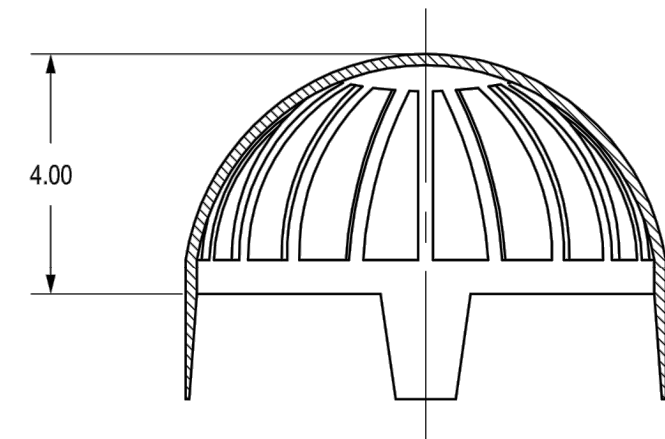

DIMENSIONS ARE FOR REFERENCE ONLY
ACTUAL DIMENSIONS MAY VARY
DIMENSIONS ARE IN INCHES
QUALITY: MATERIALS SHALL CONFORM TO ASTM A536 GRADE 70-50-05
PAINT: CASTINGS ARE FURNISHED WITH A BLACK PAINT
LOCKING DEVICE AVAILABLE UPON REQUEST SEE DRAWING NO. 7001-110-228

DOME GRATE

DRAIN BASIN

WALL MOUNT SHOULD BE INSTALLED 1.38" - 2.00" BELOW THE STRUCTURE TOP

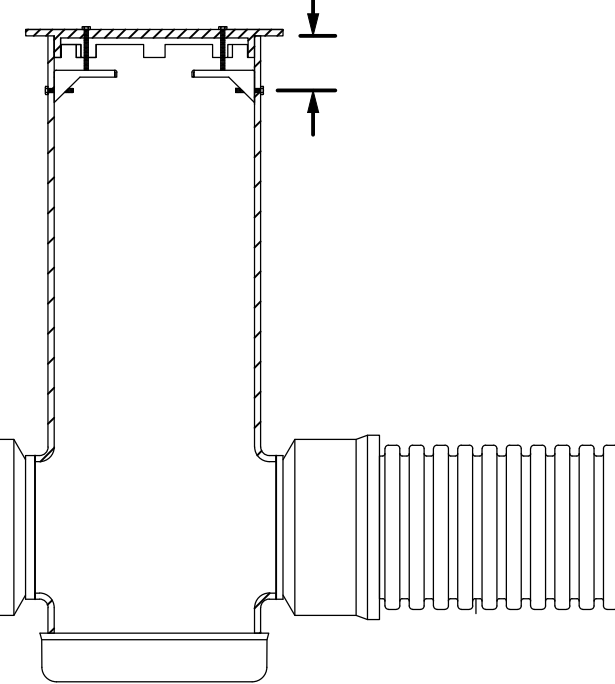

INLINE DRAIN

WALL MOUNT SHOULD BE INSTALLED 1.38" - 2.00" BELOW THE STRUCTURE TOP

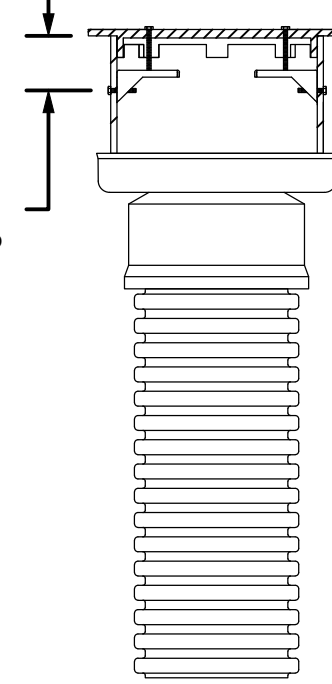

LOCKING DEVICE SHALL BE STAINLESS STEEL TO BE USED WITH PVC RISER ONLY

10 IN - 24 IN DROP-IN LOCKING KIT - P/N 1024DROLOCK

DRAINAGE NOTES

**ALL WORK THIS SHEET SUBSIDIARY TO BID ITEM
REMOVE AND REPLACE STORMWATER PUMP STATION**

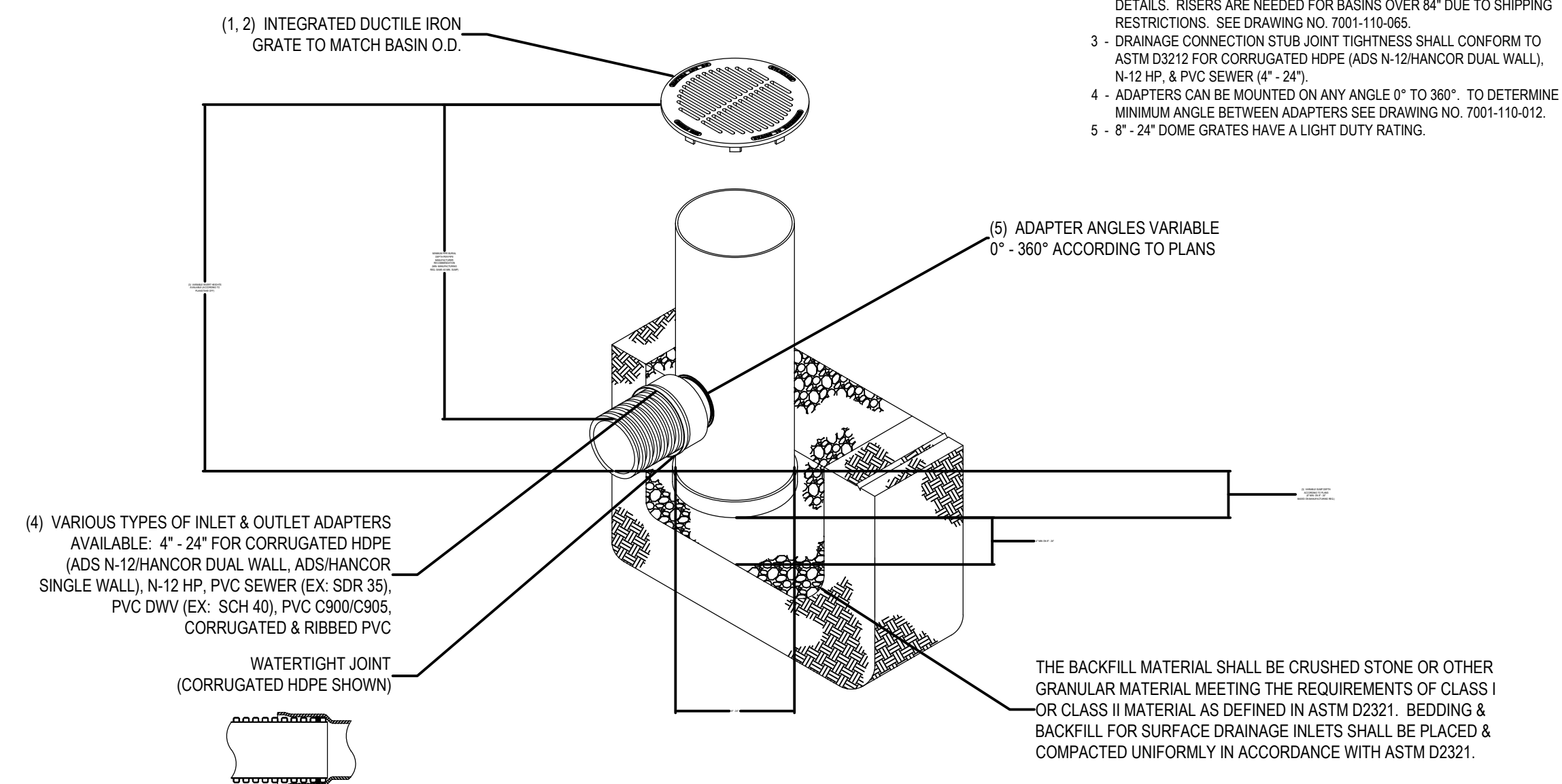

APPROX. DRAIN AREA = 39.75 SQ IN
APPROX. WEIGHT = 15 LBS

DRAIN BASIN WITH DROP-IN GRATE

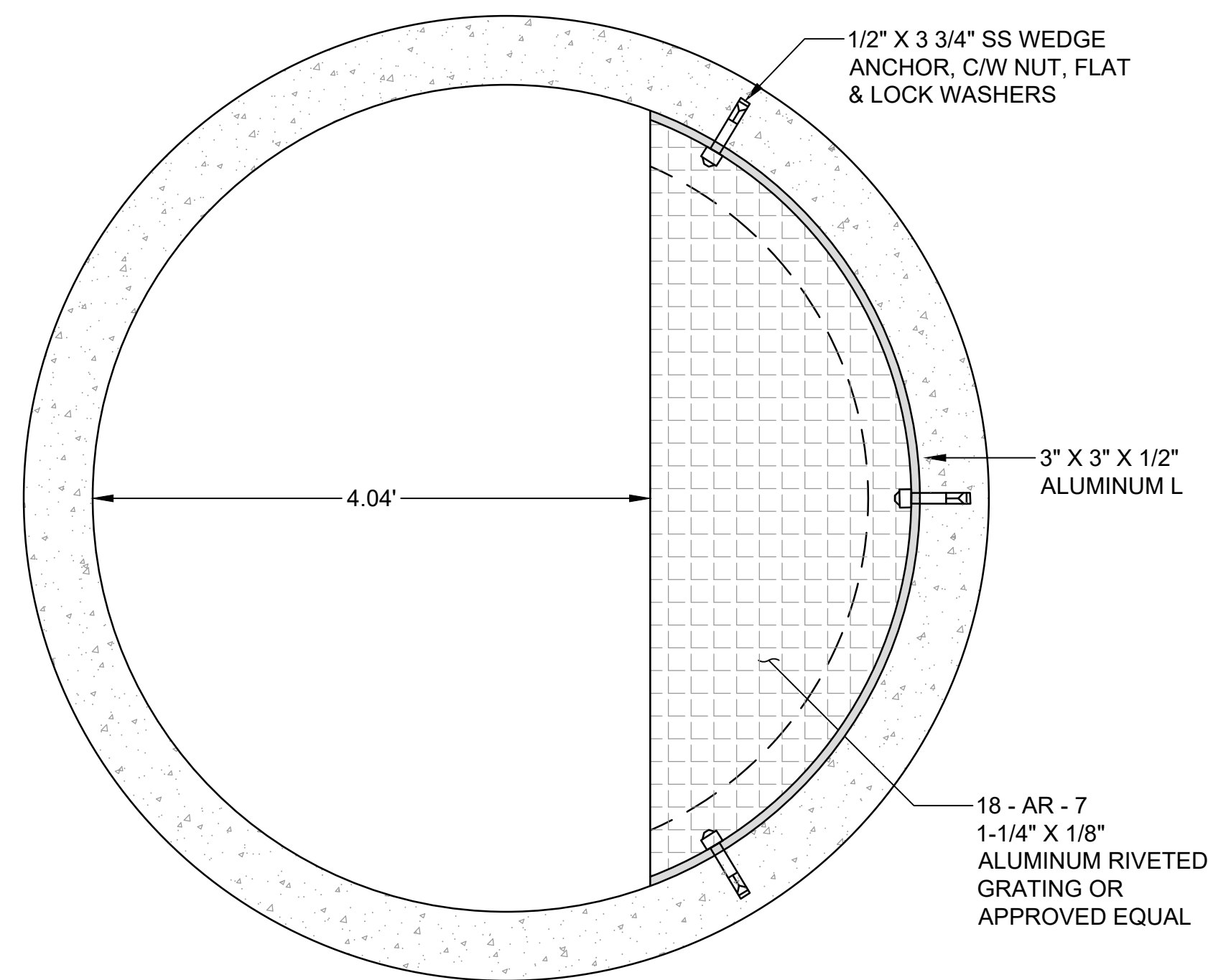

**PUMP STATION PLATFORM DETAIL
N.T.S.**

- 1 - 8" - 24" DROP-IN GRATES SHALL BE DUCTILE IRON PER ASTM A536 GRADE 70-50-05.
- 2 - DRAIN BASIN TO BE CUSTOM MANUFACTURED ACCORDING TO PLAN DETAILS. RISERS ARE NEEDED FOR BASINS OVER 94" DUE TO SHIPPING RESTRICTIONS. SEE DRAWING NO. 7001-110-065.
- 3 - DRAINAGE CONNECTION STUB JOINT TIGHTNESS SHALL CONFORM TO ASTM D3212 FOR CORRUGATED HDPE (ADS N-12/HANCOR DUAL WALL, N-12 HP & PVC SEWER (4" - 24").
- 4 - ADAPTERS CAN BE MOUNTED ON ANY ANGLE 0° TO 360°. TO DETERMINE MINIMUM ANGLE BETWEEN ADAPTERS SEE DRAWING NO. 7001-110-012.
- 5 - 8" - 24" DOME GRATES HAVE A LIGHT DUTY RATING.

THE BACKFILL MATERIAL SHALL BE CRUSHED STONE OR OTHER GRANULAR MATERIAL MEETING THE REQUIREMENTS OF CLASS I OR CLASS II MATERIAL AS DEFINED IN ASTM D2321. BEDDING & BACKFILL FOR SURFACE DRAINAGE INLETS SHALL BE PLACED & COMPACTED UNIFORMLY IN ACCORDANCE WITH ASTM D2321.

1201DI

APPROX. DRAIN AREA = 39.75 SQ IN
APPROX. WEIGHT = 15 LBS

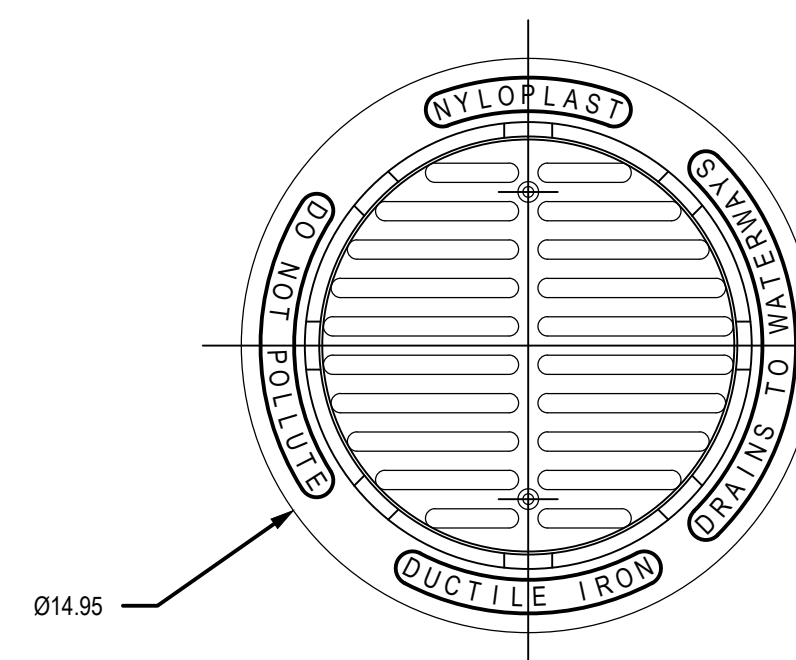

DROP IN GRATE

DIMENSIONS ARE FOR REFERENCE ONLY
ACTUAL DIMENSIONS MAY VARY
DIMENSIONS ARE IN INCHES
GRATE HAS LIGHT DUTY RATING
QUALITY: MATERIALS SHALL CONFORM TO ASTM A536 GRADE 70-50-05
PAINT: CASTINGS ARE FURNISHED WITH A BLACK PAINT
SIZE OF OPENINGS MEETS REQUIREMENTS OF AMERICAN DISABILITY ACT AS STATED IN FEDERAL REGISTER PART III, DEPARTMENT OF JUSTICE, 28 CFR PART 36.



CivilWorx

4025 Automation Way
Suite B2
Fort Collins, CO 80525
(970) 698-6046
CivilWorxeng.com

REVISIONS	DATE	BY	CHK	APP



**US30 GREENWAY PUMP STATION
DETAILS**

DATE SUBMITTED: 6/14/2021
PREPARED FOR: CITY OF CHEYENNE

SHEET NUMBER	DT02
6 OF 7 SHEETS	
SCALE	
VERTICAL: N/A	
HORIZONTAL: N/A	
JOB NUMBER	C20019

I:\Kellidier\10 - CivilWorx\Dropbox\CivilWorx\Projects\2020\C20019 - US 30 Greenway Pump Station\0899CGD\Construction_Sheet\DT_Details.dwg | 7/29/2021 5:09 PM |

REVISIONS	DATE	BY	CHK	APP

APPROVED
 Aug. 20 2021
 8:25:56 AM
 Engineering, BORU, Fire

US30 GREENWAY PUMP STATION DETAILS

DATE SUBMITTED: 6/14/2021
 PREPARED FOR: CITY OF CHEYENNE

SHEET NUMBER
DT03
 7 OF 7 SHEETS
 SCALE
 VERTICAL: N/A
 HORIZONTAL: N/A
 JOB NUMBER
C20019

**ALL WORK THIS SHEET SUBSIDIARY TO BID ITEM
 REMOVE AND REPLACE STORMWATER PUMP STATION**

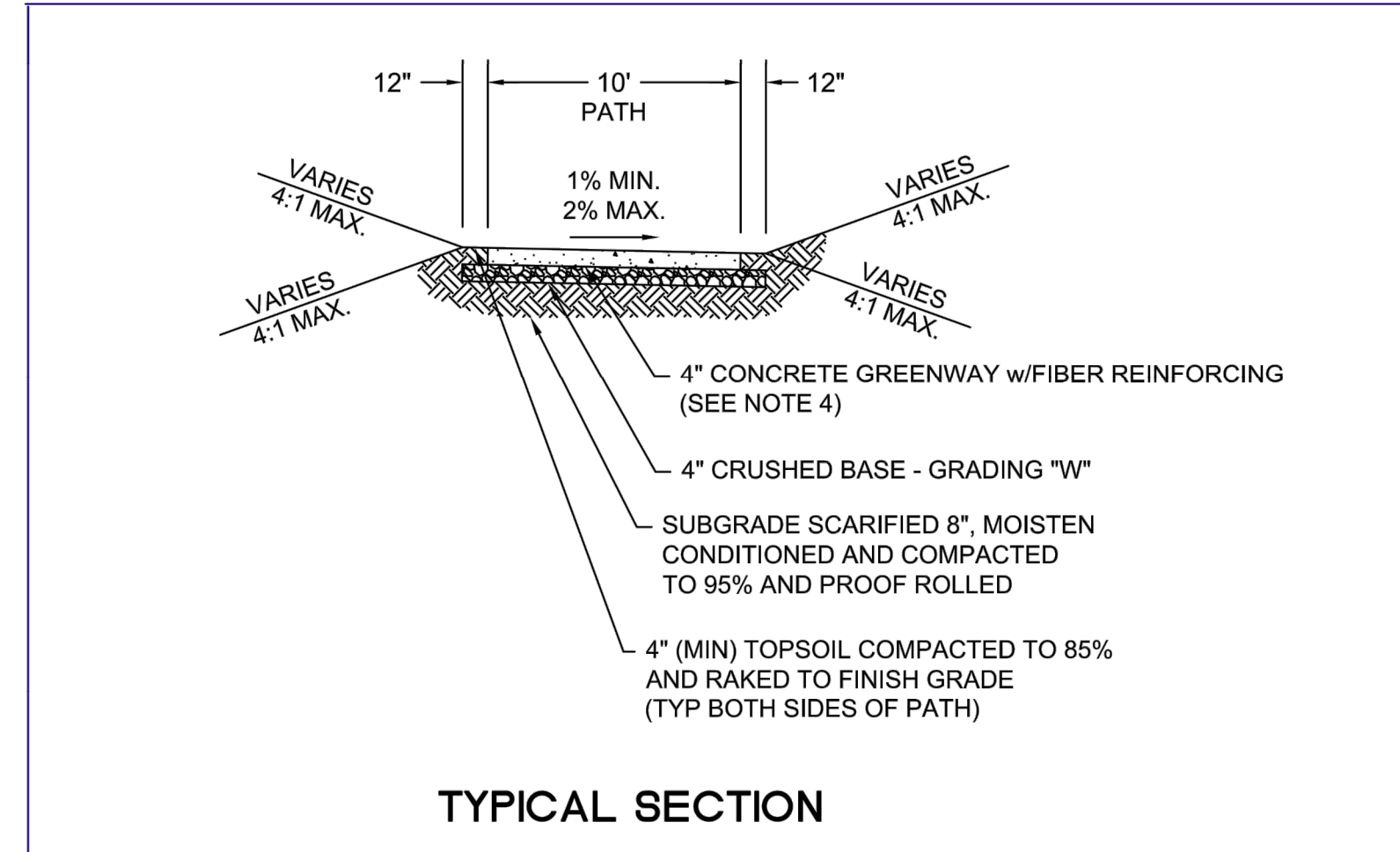
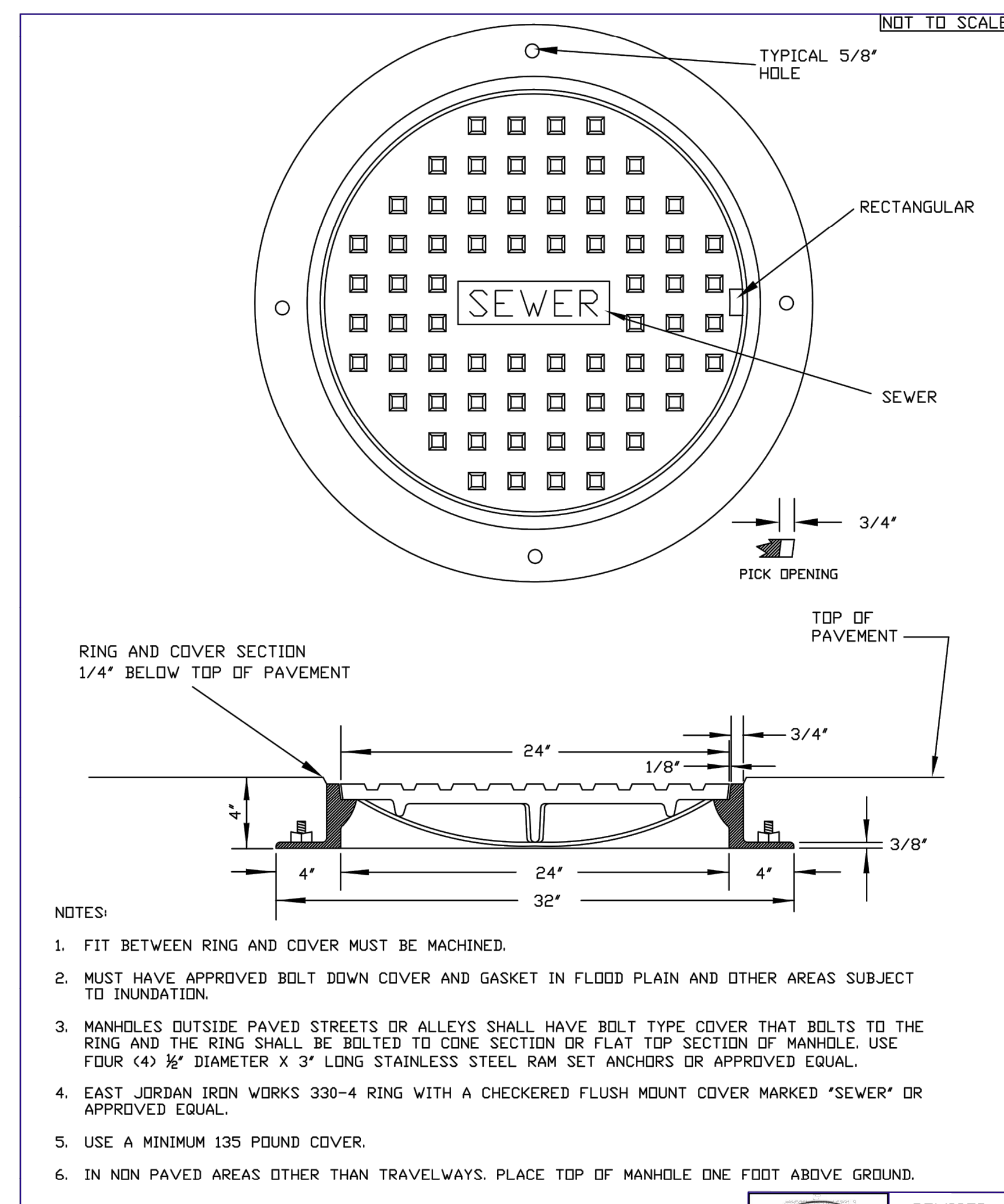
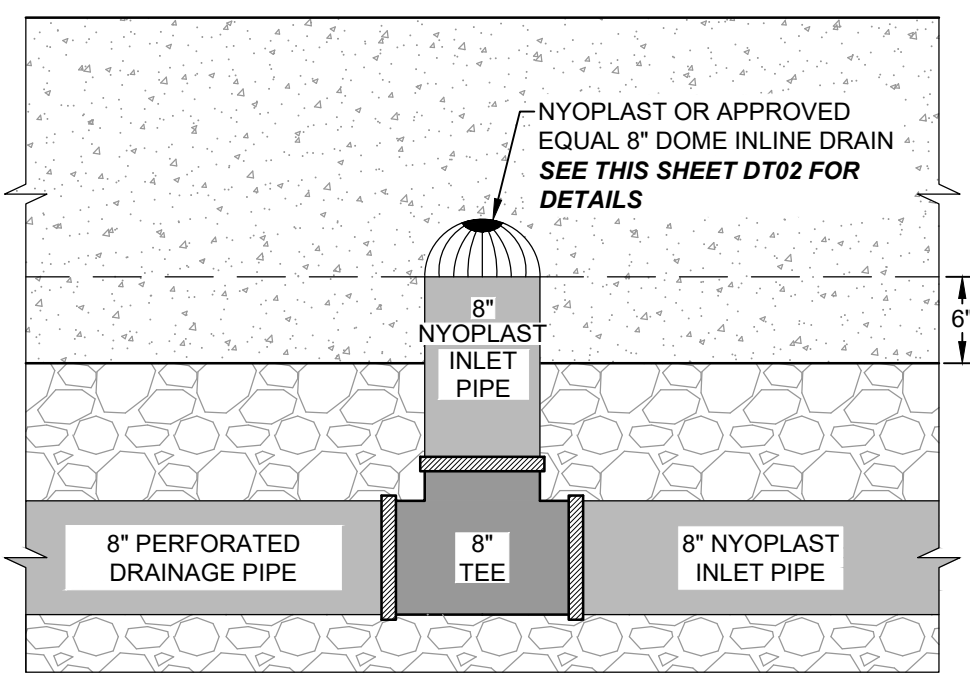
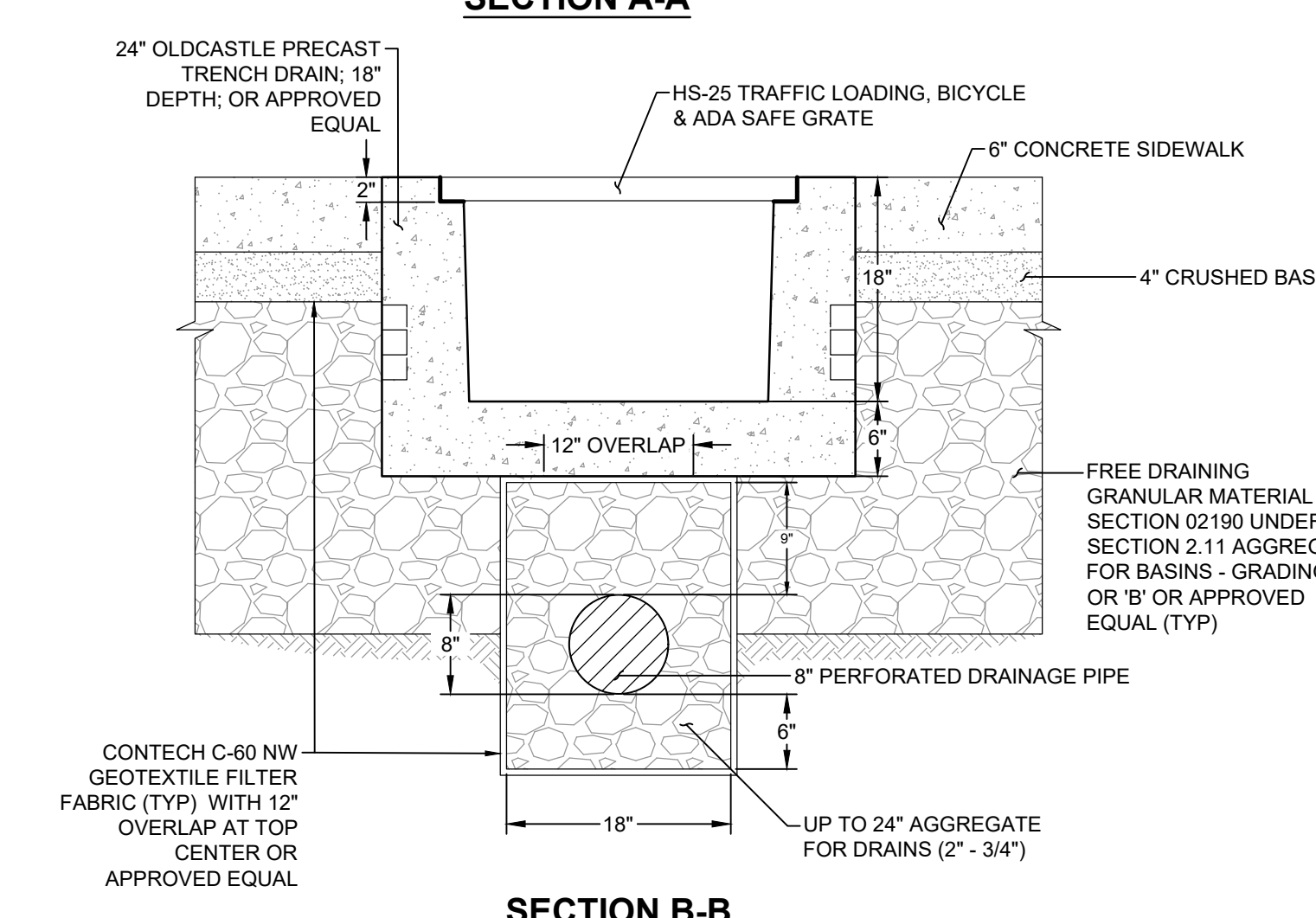
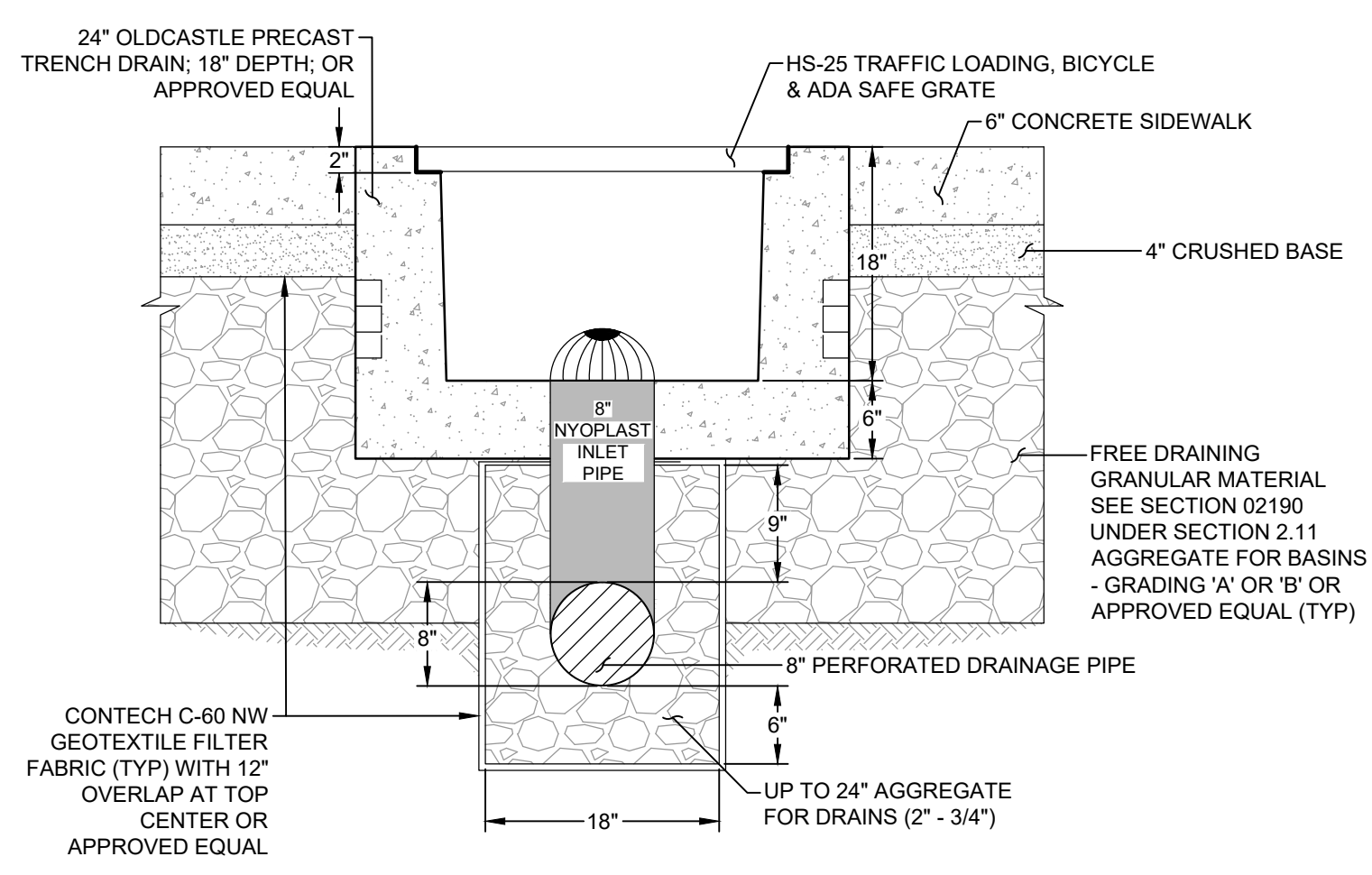
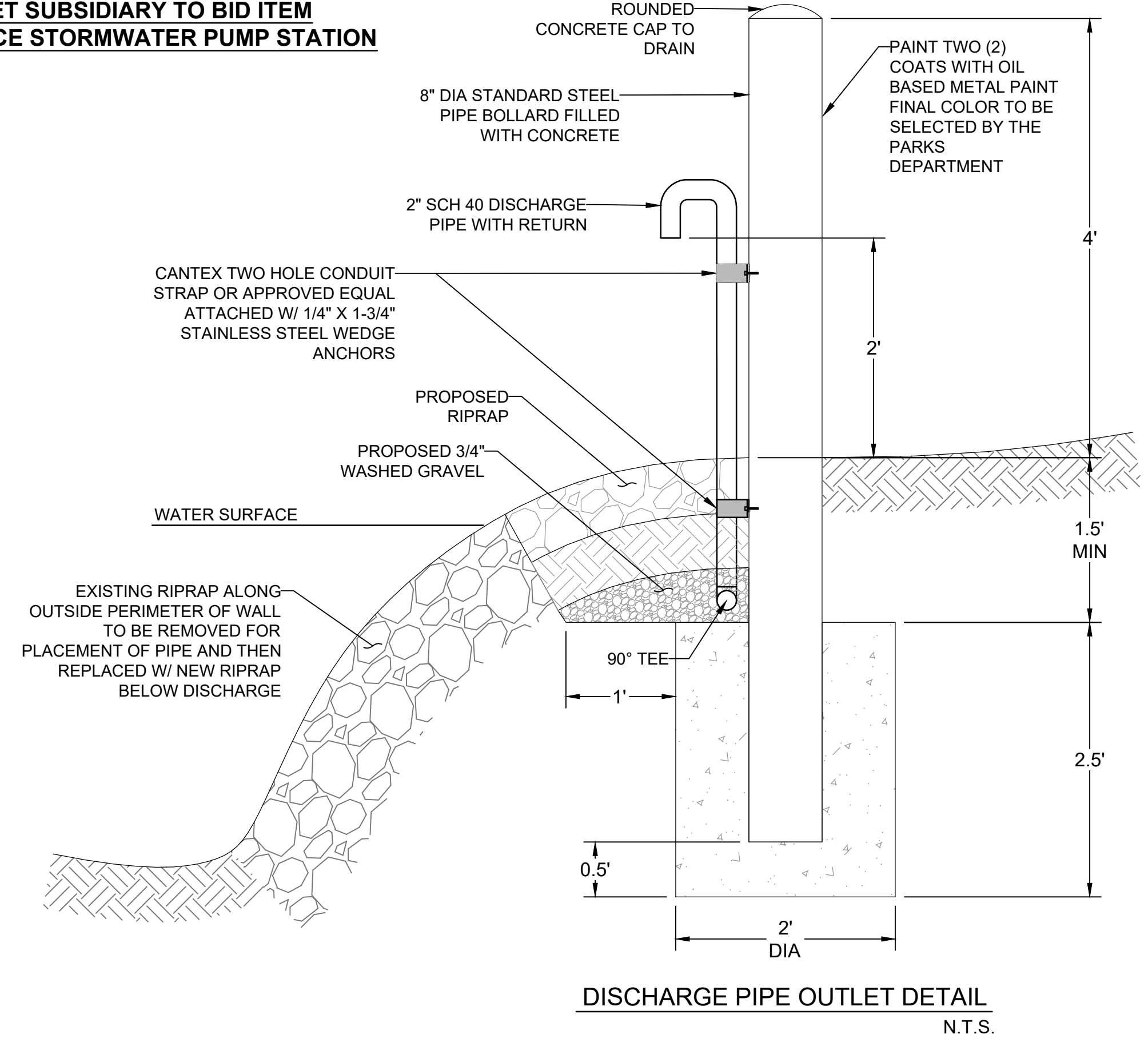
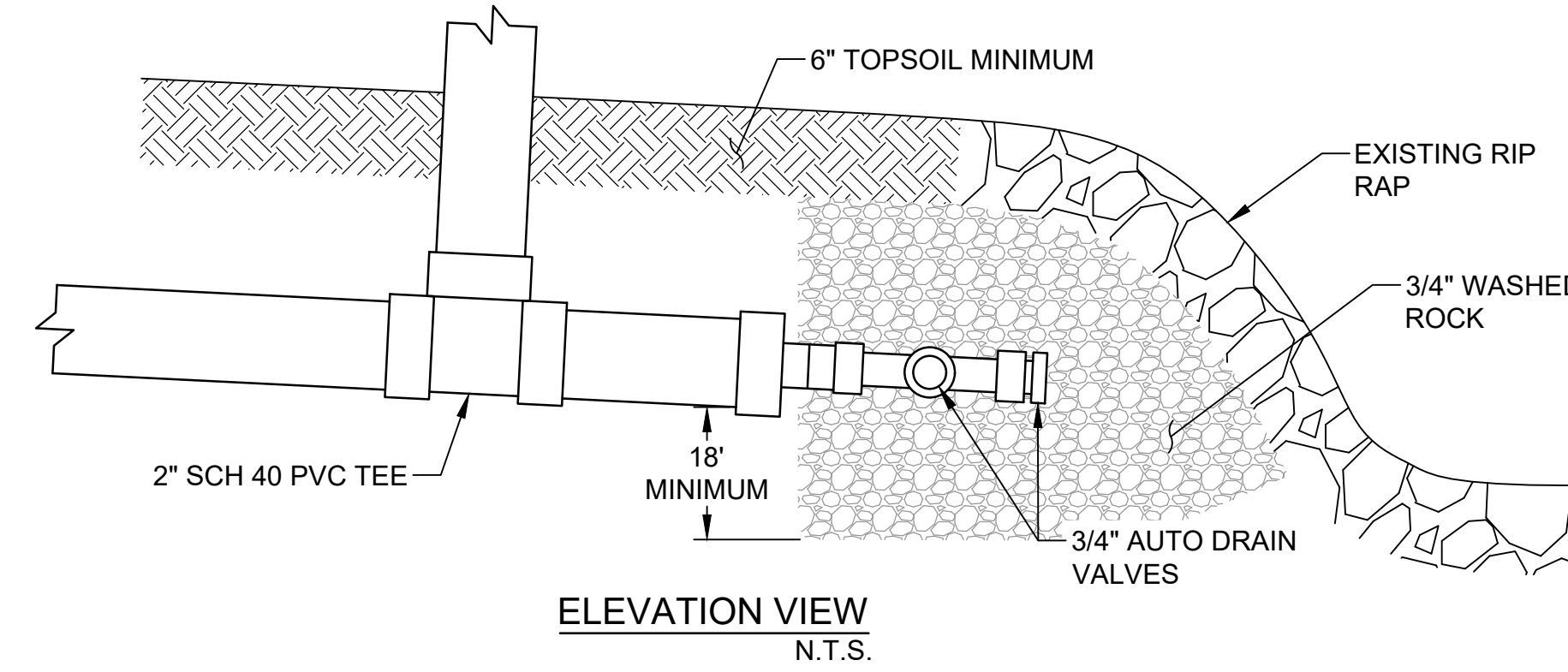
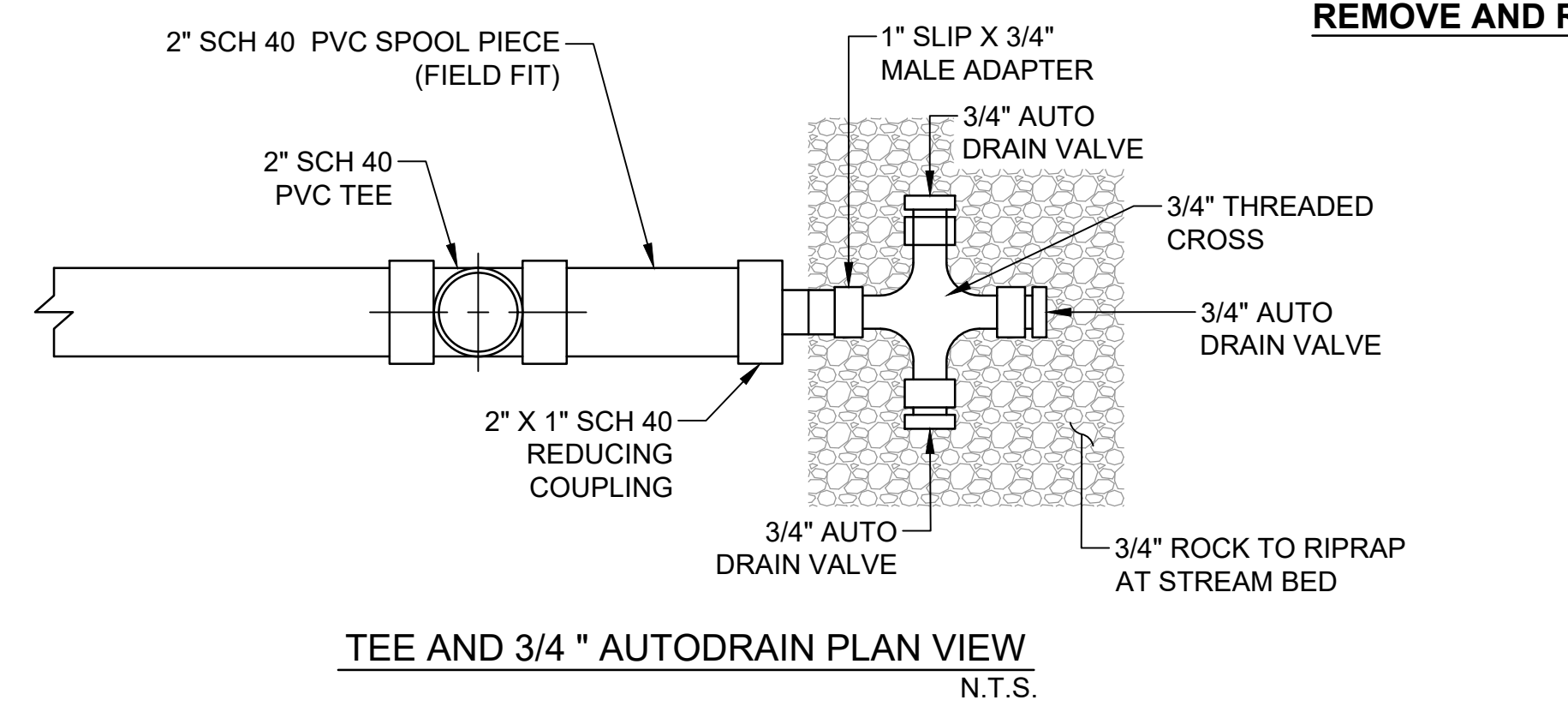
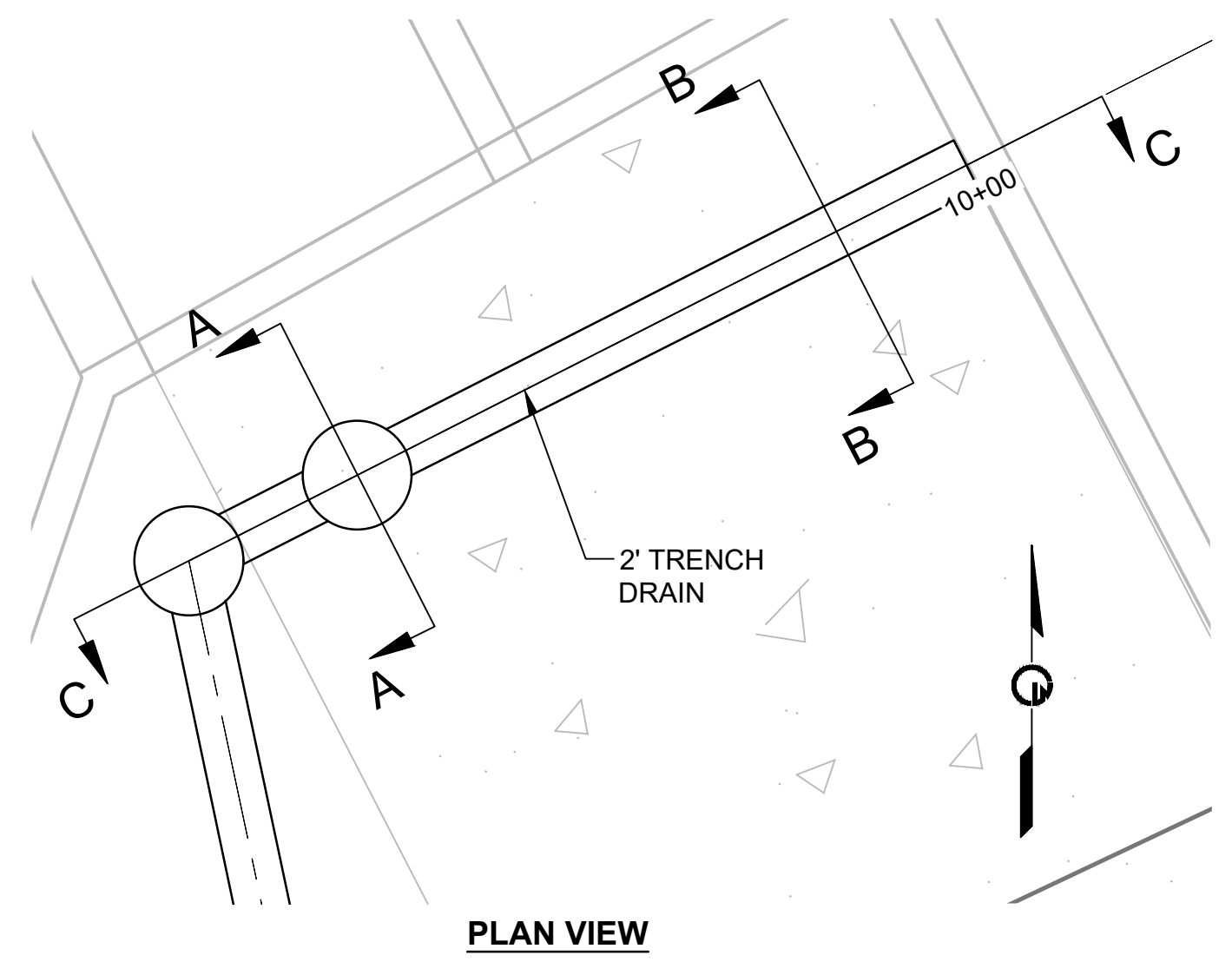

- NOTES:**
- 1.) FULL WIDTH TRANSVERSE GREENWAY JOINT SPACING SHALL BE 10'-0" (SAWCUT), 1" MIN. DEPTH.
 - 2.) EXPANSION GREENWAY JOINT SPACING SHALL BE 150'. USE PREFORMED JOINT MATERIAL FULL DEPTH. GROUT AND SEAL WITH SILICONE. EXPANSION JOINT SHALL BE CONSIDERED SUBSIDIARY TO THE GREENWAY.
 - 3.) ALL CONCRETE SHALL BE 4500 PSI WITH FIBER REINFORCEMENT AND CONFORM TO SECTION 03405.
 - 4.) ALL GREENWAY PATH WILL BE 4" THICK EXCEPT FOR ACROSS APPROACHES. THICKNESS OF DRIVE APPROACH SHALL BE 6" FOR RESIDENTIAL AND 8" FOR COMMERCIAL DRIVE AND ALLEY APPROACHES.
 - 5.) CRUSHED BASE IS TO EXTEND 12" PAST EDGE OF PATH AND COMPACTED PER SECTION 02231.
 - 6.) NO CONCRETE SHALL BE PLACED WITHOUT A FINAL FORM AND GRADE INSPECTION BY THE CITY.
 - 7.) MAX. LONGITUDINAL GRADE SHALL NOT EXCEED 5% PER ADA STANDARDS.

<p>CITY OF CHEYENNE AND BOARD OF PUBLIC UTILITIES STANDARD DRAWING</p>	<p>REVIS 2007</p>	<p>MANHOLE RING AND COVER DETAILS</p>	<p>NEW 2014</p>

<p>CITY OF CHEYENNE AND BOARD OF PUBLIC UTILITIES STANDARD DRAWING</p>	<p>GREENWAY TYPICAL SECTION</p>	<p>NEW 2014</p>	<p>STANDARD DRAWING NO. 03340-11</p>
---	---------------------------------	------------------------------	--

ADMINISTRATIVE INSTRUCTIONS

TABLE OF CONTENTS

1.00	VALUE ENGINEERING.....	1
2.00	REFERENCES.....	1
2.01	Coordination of Contract Documents	1
2.02	Reference Specifications	2
3.00	TRAFFIC CONTROL.....	2
3.01	Construction Phasing.....	2
3.02	Traffic Control Requirements	3
3.03	Notifying Affected Parties	3
3.04	Parking Restrictions	3
3.05	Traffic Disruption and Obstructions	3
3.06	Property Access.....	4
3.07	Emergency Access	4
4.00	CONTROL OF WORK.....	4
4.01	Construction Stakes, Lines, and Grades.....	4
4.02	Land Provided by the City	5
4.03	Land Provided by the Contractor	5
4.04	Protection and Restoration of Property, Markers, and Landscape.....	6
4.05	Cooperation by the Contractor	7
4.06	Cooperation between Contractors	8
4.07	Maintenance during Construction	8
5.00	CONTROL OF MATERIAL.....	8
5.01	Inspection and Testing for Quality Control.....	8
5.02	Unacceptable Materials	9
5.03	Storage of Materials	10
5.04	City-Furnished Material	10
5.05	Rights In and Use of Material Found in the Work.....	10

5.06	Removal and Salvage of Materials.....	11
5.07	Material Spoil Area/Waste Site.....	11
5.08	Load Restrictions.....	11
6.00	RESPONSIBILBILTY FOR UTILITY PROCEDURES AND SERVICES.....	12
6.01	Location.....	12
6.02.	Utility Line Conflicts and Damage.....	12
7.00	WORK SCHEDULE AND CONDITIONS.....	13
7.01	Pre-Construction Conference	13
7.02	Weekly Conference	13
7.03	Work Progress	13
7.04	Working Days and Time	13
7.05	Schedule	15
7.06	Requirements for Workers, Methods, and Equipment.....	17
7.07	Suspension of Work	17
7.08	Extension of Contract Completion Date	19
7.09	Concurrent Delays.....	19
7.10	Weather Days	20
8.00	MEASUREMENT AND PAYMENT.....	20
8.01	Measurement of Quantities	20
8.02	Compensation for Altered Quantities.....	21
8.03	Monthly Progress Payment	21
8.04	Payment for Material on Hand.....	21
9.00	MOBILIZATION	22

1.00 VALUE ENGINEERING

A Value Engineering Proposal (“VEP”) is a creative proposal initiated by the Contractor to amend the Contract to use an alternate method, design, material, or similar element, to reduce the project’s cost or improve its outcome for both the City of Cheyenne’s (the “City’s”) and the Contractor’s benefit.

The Contractor may submit a VEP for consideration by the City and the City Engineer (the “Engineer”) after the City awards the contract. The Contractor shall submit a VEP in accordance with the procedure outlined in the current edition of the Wyoming Department of Transportation Standard Specifications for Road and Bridge Construction (“WYDOT Standard Specifications for Road and Bridge Construction”), Subsection 104.3.4, “Submitting a VECF”.

The City will not consider VEPs that are cost reductions resulting from corrections to design errors; that are inconsistent with the City’s design policies and criteria for the project; or that may require excessive time or cost for review.

If the City and the Engineer accept a VEP which results in a net reduction in the contract price, the Contractor will share proportionally with the City in the net savings (City 50%; Contractor 50%), less the cost of the Engineer’s time required to evaluate the VEP. Net savings are defined as savings available after deducting VEP evaluation costs.

2.00 REFERENCES

2.01 Coordination of Contract Documents. Revise City of Cheyenne & Board of Public Utilities Standard Construction Specifications and Standard Drawings, 2014 Edition (“City Standard Specifications and Drawings” or separately as “Standard Specifications” or “Standard Drawings”) Section 01090, REFERENCES, item 1.01.A. as follows, by deleting the hierarchy list included (items 1 thru 4), and replace with the following in order of precedence:

1. Permits from other agencies as required by law;
2. Successive change orders and contract modifications in order of issuance, most recent first;
3. Addenda;
4. Contract;
5. City-obtained agreements;
6. Special Provisions;
7. General Conditions;
8. Project Plans;
9. Standard Drawings;

10. Standard Specifications;
11. Electronic CADD Files; and
12. Reference Specifications.

Detailed plans shall have precedence over general plans.

2.02 Reference Specifications. The City Standard Specifications and Drawings, and all revisions through the advertisement date, constitute the current Standard Specifications and Standard Drawings for this project. They are an integral part of the Contract and are incorporated herein by reference. The Contractor shall adhere to all requirements and provisions of said City Standard Specifications and Standard Drawings in the performance of this Contract, except where otherwise provided herein or otherwise shown on the Contract Drawings.

Contract references to standard test methods or specifications such as those from the American Association of State Highway and Transportation Officials (“AASHTO”), the American Society for Testing and Materials (“ASTM”), or similar professional organizations, refer to the methods and specifications in effect on the advertised date of the public bid opening. If a later change to a cited document affects successful completion of the project, the City will incorporate the new reference with a contract modification.

All work shown on the Contract Drawings and Standard Specifications which refer to the Wyoming Department of Transportation (“WYDOT”) shall be constructed in accordance with the current editions of the WYDOT Standard Specifications for Road and Bridge Construction and WYDOT Standard Plans and all revisions through the date of advertisement.

It is the bidder’s responsibility to acquire the latest editions of all the Specifications, Standard Drawings, and Manuals.

3.00 TRAFFIC CONTROL

3.01 Construction Phasing. When a construction phasing or traffic control plan is included in the project plans, this plan shall govern unless an alternate plan, acceptable to the City, is submitted to the Engineer by the Contractor. If no traffic control plan is provided or if the Contractor desires to deviate from the provisions for maintaining traffic as described in the contract documents, the Contractor shall submit to the Engineer for approval a proposed sequence of operations and a compatible method of maintaining vehicle, pedestrian, and bicycle traffic. The Contractor shall submit the proposal for review and approval at least ten (10) Working Days prior to its intended implementation. The City reserves the right, in its sole discretion, to reject any construction phasing or traffic control proposal for any reason whatsoever.

- 3.02 Traffic Control Requirements.** The Contractor shall provide adequate signs, barricades, lights, flares, flaggers, take all necessary precautions to prevent accident or injury, and minimize the public’s inconvenience while the work is in progress. Any traffic control or construction phasing drawings shown in the project plans are conceptual only. The Contractor shall submit a detailed traffic control diagram to the City for prior approval before work begins. The diagram shall indicate location and type of signs, cones, flashers, flagging, reflective barricades, and all other devices the Contractor deems necessary for the proper protection of the work area. The Contractor shall install and maintain all traffic control and protective devices in accordance with the current edition of the Manual on Uniform Traffic Control Devices for Streets and Highways (“MUTCD”).
- 3.03 Notifying Affected Parties.** The Contractor shall notify all homeowners and businesses it anticipates will be affected by any work no less than two (2) Working Days, as defined by section 7.04, “Working Days and Time”, before work is scheduled to commence. All written notifications shall be approved by the City prior to distribution. The Contractor shall notify all homeowners and businesses again if the work does not begin on the specified day, as anticipated. The notice shall be a written posting, hand delivered to the property, stating the anticipated start-date and duration of such work containing parking restriction information, and a phone number for the Superintendent or Project Manager. The Contractor shall not place notices in mailboxes.
- 3.04 Parking Restrictions.** If work requires parking restrictions, the Contractor shall place “No Parking” signs along the affected area a minimum of forty-eight (48) hours prior to the beginning of work. The Contractor shall place “No Parking” signs a maximum of seventy-five (75) feet apart, but at no time fewer than two per block, per side. The City will only tow vehicles from the work area if they remain parked on the street after the Contractor provided proper written notice and placed “No Parking” signs. If the Contractor provides insufficient notice to affected parties, the Engineer must approve towing vehicles parked on the street, and such towing shall be at the Contractor’s expense.
- 3.05 Traffic Disruption and Obstructions.** The Contractor shall minimize obstructions to vehicle, pedestrian, and bicycle traffic; minimize disruption to transit routes; and give consideration to the location of detours and provisions for handling traffic. The Contractor shall provide for the safety and convenience of both the general public and residents near the work. The Contractor’s travel rights do not supersede the public’s travel rights.

Whenever, in the Engineer’s opinion, the Contractor has not provided sufficient or proper safety precautions, the Contractor shall do so immediately and to whatever extent the Engineer requires. This provision shall not be construed as creating any duty on the part of the Engineer for traffic safety.

Fire hydrants on or near the site of the work shall be accessible at all times.

The Contractor shall not close any streets, driveways, access points, or any transit stops without prior consent of the City, Engineer, and proper governmental authorities affected by the closure or having authority over such area. The Contractor is required to request approval from the Engineer at least five (5) Working Days prior to the planned date of physical closure of any street or transit stop. Submittal or approval of a traffic control plan alone does not constitute notice or approval of the date of start of closure.

3.06 Property Access. The Contractor shall provide temporary approaches to businesses and residences adjacent to the roadway, intersections, detours, crossings, or similar features or facilities to safely accommodate customary vehicular or pedestrian traffic affected by the work.

3.07 Emergency Access. The Contractor shall be prepared at all times to provide immediate access for emergency vehicles to any buildings or other areas adjacent to the project and shall, upon emergency personnel request, construct temporary ramps and other facilities required for such emergency access. The City will make no additional payment to the Contractor for any delays or cost incurred by the Contractor in providing such emergency access.

4.00 CONTROL OF WORK

4.01 Construction Stakes, Lines, and Grades. The Contractor shall provide all construction surveying and stakeout required to accurately build and complete the project. The Engineer will establish primary project control only, but if the Engineer determines that additional project control is needed, the Engineer may direct the Contractor to establish additional project control under the direct supervision of a licensed Wyoming Professional Land Surveyor. The Engineer may provide an electronic point file or CADD files to the Contractor for use in construction staking.

The Contractor shall preserve all survey stakes and marks. If any of the primary project control survey marks are destroyed or disturbed due to the Contractor's construction activities or negligence, the Contractor shall be charged at the Engineer's established hourly crew rate for replacing them, with payment for this extra work made directly to the City's Consultant by deduction from the monthly periodic estimate payments to the Contractor. The Contractor shall also be responsible for any mistakes or damage resulting from the unnecessary loss or disturbances of control points, offset line points, and stakes.

The Contractor is responsible for scheduling all surveying and shall consider all phasing, sequencing, and construction limits required by all specifications. The Contractor shall review the survey stakes to ensure there is no discrepancy between the drawings and the survey stakes. If there is a discrepancy, the Contractor shall stop work immediately and notify the Engineer without delay.

The Contractor shall provide the survey data to the Engineer to verify elevations, resolve grade issues, and to otherwise use as the Engineer deems necessary or appropriate. The Engineer has the right to review the project stakeout prior to staking. The Contractor shall arrange work to allow forty-eight (48) hours advance notice for the Engineer to review the lines and grades of those stakes set for the next step of the Contractor's work. The Engineer shall have the right to make reasonable changes in the grades as shown on the drawings. The Engineer will be available for consultation and interpretations for staking operations.

The Contractor shall call to the Engineer's attention any reference lines, points, or bench marks, which may have been disturbed or appear off line or grade.

A licensed Wyoming Professional Land Surveyor shall directly supervise all construction surveys. The costs for providing all construction surveying and staking shall be considered included in the cost of contract items.

4.02 Land Provided by the City. The City or Engineer will obtain all easements and franchises required for the work. The Contractor shall limit operations to the area obtained and shall not trespass on private property. The City may provide access to certain lands, as indicated in connection with the work under the contract. The Contractor shall not conduct any activity on any land which may result in the imposition of any lien or encumbrance. The Contractor shall use said land in accordance with conditions established by the City.

4.03 Land Provided by the Contractor. If the Contractor requires additional area required for temporary construction facilities or storage of materials, the Contractor shall obtain written consent and agreement from the landowner on whose land the Contractor seeks to expand the Contractor's operation. The Contractor must provide a copy of this agreement to the Engineer, who may grant or deny permission to expand to additional land. The agreement, if accepted by the Engineer, must describe the activity for which the land will be used and how the Contractor will restore the land.

The Contractor shall construct all access roads, detour roads, or other temporary works, as required by the operations. The Contractor shall confine its equipment, materials storage, and worker operations to those areas shown and described, and such additional areas as the Contractor may provide. The Contractor shall provide such land, and access thereto, without liability to the City.

Prior to final payment, the Contractor shall furnish the Engineer with a written statement of clearance from the landowner for those properties on which work, equipment, or material staging took place.

4.04 **Protection and Restoration of Property, Markers, and Landscape.**

General: All construction work under this contract on rights-of-way, easements, or franchise, shall be confined to the limits of such rights-of-way, easements, or franchise. The Contractor shall accomplish all work so as to cause the least amount of disturbance and a minimum amount of damage. The Contractor shall take all necessary precautions to preserve and protect adjacent roadways, public and private properties and improvements, and underground facilities during work on the project. The Contractor shall take responsibility for any damage or injury resulting from:

1. Any act, omission, negligence, or misconduct in the execution of the work;
2. Defective work or materials; and
3. The work of a Subcontractor.

Except for damage due to unforeseeable causes beyond the control of, and without fault of negligence of the Contractor, the Contractor shall rebuild, repair, restore, and make good damages to any portion of the project or real property injured in the course of the work, from any cause before final acceptance, and without additional cost to the City.

The Contractor shall coordinate such repairs, replacements, or both, of real property with the affected property owner, and obtain the property owner's written approval when the final work is complete. A copy of the property owner's approval shall be submitted to the City. If the Contractor fails to perform such restoration within a reasonable time, the City may do so and deduct the cost from monies due the Contractor or bill the Contractor, as appropriate.

The Contractor's responsibility for the work lasts until final written acceptance of the project by the City, in accordance with General Conditions regarding Completion and Warranty.

Site security: The Contractor shall provide site security in accordance with Special Provisions Section 01231, SAFETY. Suspension of work does not relieve the Contractor of responsibility for the project, except in accordance with General Conditions provisions on Suspension of Work.

Vehicle Damage Claims: If a vehicle owner makes a vehicle damage claim, the Contractor shall send a written response to the claimant addressing the claim and the actions the Contractor has taken or intends to take. The Contractor shall send a copy of the response letter to the following address:

City of Cheyenne Risk Management
Attn: Risk Manager
2101 O'Neil Ave
Cheyenne, WY 82001

Trenches: The Contractor shall not leave trenches open across travel ways for more than twenty-four (24) hours or over weekends or holidays. Trenches that present a danger to vehicular or pedestrian traffic shall be backfilled or barricaded at the end of each day's work.

Structures: The Contractor shall remove such existing structures as may be necessary for the performance of the work and, if required, shall rebuild the structures thus removed in as good a condition as found with minimum requirements as herein specified. The Contractor shall also repair all existing structures damaged as a result of the work under this contract.

Cultivated Areas and Other Surface Improvements: All cultivated areas, either agricultural or lawns, and other surface improvements damaged by Contractor's actions shall be restored as nearly as possible to their original condition and in accordance with Standard Specification, Section 02900, Landscaping. Prior to excavation on an easement or private right-of-way, the Contractor shall strip topsoil from the trench or construction area and stockpile it in such a manner that it may be replaced by the Contractor upon completion of construction. Ornamental trees and shrubbery shall be carefully removed, with the earth surrounding their roots, wrapped in burlap and replanted in their original positions within twenty-four (24) hours. The Contractor shall replace all shrubbery or trees destroyed or damaged with material of equal quality at no additional cost to the City or property owner.

In the event that it is necessary to trench through any lawn areas, the sod shall be carefully cut, rolled, and replaced after the trenches are backfilled. The Contractor shall then clean the lawn area of debris by raking or other means. All fences, markers, mail boxes, or other temporary structures shall be removed by the Contractor and immediately replaced after the trench has been backfilled, in their original positions. The Contractor shall notify the Engineer and property owner at least twenty-four (24) hours in advance of any work done on easements or private rights-of-way.

Streets: The Contractor shall assume all responsibility for restoration of the surface of all streets (travel ways) used by the Contractor and damaged.

4.05 Cooperation by the Contractor. Contact and Emergency Response: The Contractor shall maintain a telephone for the duration of the contract, at the Contractor's own expense, where the Contractor or the Contractor's authorized representative may be reached directly or by message at all times, including weekends and holidays. The Contractor shall cooperate with the Engineer and inspectors at all times and shall respond to requests for emergency repairs to the contract work no later than two (2) hours of the request.

If the Contractor does not respond to requests for emergency repairs within the time allotted, the City reserves the right to enter the work area and conduct repairs with

City forces or City-hired forces. The Contractor will be responsible for all costs incurred by the City in responding to the emergency repairs and will also be responsible for restoring all work back to the required contract conditions. The City will not be responsible for any damages to the Contractor's work or equipment that results from the City responding to the emergency repair.

Superintendence: When work is underway, including work by a Subcontractor, the Contractor shall ensure the presence of a competent project superintendent, who is an employee of the Contractor, at the worksite at all times, unless otherwise agreed to by the City. The project superintendent shall have the ability to communicate clearly; to read, interpret, and implement the relevant contract documents; have experience in the work included in the project; have authority to represent and act for the Contractor, including authority to execute the Engineer's directions; and authority to obtain and provide sufficient materials, equipment, tools, labor, and incidentals to complete the project as specified.

4.06 Cooperation between Contractors. The City may contract with separate Contractors for additional work on or near the worksite. When separate contracts are let, the City requires each Contractor to cooperate with and work without hindering each other.

Each Contractor assumes liability, financial or otherwise, for its own errors, acts, or omissions and holds the City harmless, in accordance with the General Conditions of the Contract, from damages or disputes arising from inconvenience, delay, or loss due to the presence and operations of other persons, contractors or public entities on or near the worksite.

4.07 Maintenance during Construction. The following shall be added to Standard Specification Section 01054.1.09:

The Contractor is responsible for snow removal within all barricaded areas of the project. The Contractor will be responsible for snow removal within the travel way of the project area unless a minimum of a 16' lane is provided for the City plows.

5.00 CONTROL OF MATERIAL

5.01 Inspection and Testing for Quality Control. Requirements: All materials and work shall be tested and inspected in accordance with the specifications. The Contractor shall provide testing and inspection services to verify compliance with requirements specified or indicated. The Contractor shall be responsible for scheduling inspections and tests and notifying the laboratory.

The Contractor shall provide advance notification to the Engineer of any testing or sampling to be conducted. The Engineer may provide Quality Assurance testing to prevent against defects and deficiencies in the Contractor's work by verifying that

the Contractor's Quality Control testing is accurate and adequate. However, furnishing such Quality Assurance testing shall not relieve the Contractor of responsibility for providing Quality Control testing or responsibility for the Contractor's failure to perform the work in accordance with the contract documents.

Laboratory Requirements: The Contractor shall retain the services of an Independent AASHTO-accredited testing laboratory to inspect, sample and test the related work. The testing laboratory shall cooperate with the Engineer and the Contractor in performing its duties and shall provide qualified and/or certified personnel to perform inspections and tests.

Tests shall be performed in accordance with the most recent cited standard methods of AASHTO or ASTM, approved AASHTO Interim Specifications, or ASTM Tentative Specifications in effect on the advertised date of the public bid opening or more stringent Quality Control requirements where specified in the Special Provisions.

The testing laboratory shall promptly notify the Engineer and the Contractor of deficiencies in the work observed during the performance of its duties. The testing laboratory shall not approve or accept any portion of the work nor shall it perform any duties of the Contractor.

Submittals: The testing laboratory shall submit a certified written report of each inspection and test to the Engineer, Contractor, and any other entities designated by the City. Copies of all test results shall be provided to the City within twenty-four (24) hours of the availability of the test results with written report to follow within seven (7) Working Days. Reports of each inspection, test, or similar service shall include the following:

1. Name, address, and telephone number of testing laboratory.
2. Project title and project number.
3. Date of report and designation (number).
4. Dates of testing and maps with sufficient detail to accurately identify locations where samples were taken or inspections and field tests made.
5. Ambient conditions at the time of sample taking and inspecting, or field testing.
6. Names of individuals taking the sample or making the inspection or test.
7. Product and test method.
8. Inspection or test data including interpretation of test results and comments or professional opinion on whether inspected or tested work complies with requirements.
9. Recommendations on retesting or re-inspections.
10. Name and signature of laboratory inspector.

5.02 Unacceptable Materials. The Contractor shall not undertake any work in which untested or non-conforming materials are used without prior, written, express approval from the Engineer. Any such work undertaken using untested or non-

conforming materials without the prior, written, express approval of the Engineer may be considered in material breach of this contract and, if directed by the City, shall be removed at no additional cost to the City.

5.03 Storage of Materials. Materials shall be stored, in accordance with manufacturer's recommendations, and handled in a manner that facilitates inspections and preserves the materials' quality and suitability for use. Material shall be transported in vehicles built to prevent loss, contamination, or segregation after loading and measuring. The Engineer may re-inspect stored, previously inspected materials before approving their use in the work.

As approved by the City, that portion of the right-of-way within the project limits not required for public travel may be used for storage purposes and for placing of the Contractor's plant and equipment. Material stored on or adjacent to public streets shall not create a safety hazard, obstruct, or inconvenience the traveling public. Any additional space required must be provided by the Contractor at the Contractor's expense. Private or public property shall not be used for storage purposes without written permission of the owner or lessee. All storage sites shall be restored to their original condition by the Contractor at the Contractor's sole expense. Construction materials may not be stored in streets, roads, or highways for more than five (5) days after unloading. All materials or equipment not installed or used in the construction within five (5) days after unloading shall be stored elsewhere by the Contractor at the Contractor's expense, unless the Engineer authorizes additional storage time.

Excavated material, except that which is to be used as backfill in the adjacent trench, may not be stored in public streets, roads, or highways unless the Engineer authorizes such storage. Erosion control shall be provided around all excavated or backfill material. After placing backfill, all excess material shall be removed immediately from the site.

5.04 City-Furnished Material. If specified in the Special Provisions, the City will provide material for incorporation into the project. Materials furnished by the City will be delivered, or made available to the Contractor, at the locations specified in the Special Provisions.

The cost of handling and placing all materials supplied by the City shall be considered as included in the contract price for the item in connection with which they are used.

The Contractor shall be held responsible for all material delivered to him, and deductions shall be made from any money due to make good any shortages or deficiencies, from any cause whatsoever and for any damage which may occur after such delivery and for any demurrage charges.

5.05 Rights In and Use of Material Found in the Work. The City may authorize the

use of aggregate or other material found in excavation for use in another pay item. The City will pay the established contract unit price for excavation of such material and for the pay item for which it was used. If the excavated material is used for another pay item but was otherwise needed for embankments, backfills, approaches, or other purposes, the Contractor shall provide an acceptable replacement at no additional cost to the City.

The Contractor shall not excavate or take material outside the slope stake limits without the City's prior written approval. The right to use and process material found within the project limits excludes use and processing for noncontract work. If the Contractor produces or processes more material from the project than is required for the contract, without additional compensation to the Contractor, the City may take possession of the excess material and direct its use; or require removal of the material and restoration of the land to a satisfactory condition.

5.06 Removal and Salvage of Materials. Any equipment, hardware, structures, inlet grates, valve boxes, manhole rings, covers and lids, traffic control standards, signs and posts, fence and any other miscellaneous items designated for removal from the site and salvage to the City shall be removed from the site and taken to a location designated by the City. All such materials shall be the property of the City unless otherwise specified. Diligent care shall be taken during the removal of all materials to prevent damage.

Manhole covers and manhole rings designated for salvage shall be both plainly marked with a durable, exterior paint for easy identification as individual pairs.

5.07 Material Spoil Area/Waste Site. The Contractor shall notify the Engineer at the preconstruction conference as to the location selected to dispose of the excess, waste and unsuitable materials and a map indicating the haul route for the removal from the project.

Lost and spilled materials onto the route taken by the Contractor shall be promptly removed. The route shall be maintained as deemed necessary by the Engineer by the use of water trucks, motor grader, hand labor and related equipment to alleviate the problem of lost spills, tracked mud, and dust control. Prompt restoration of the route is required.

No extra compensation shall be allowed for the disposal of the waste and surplus material; including but not exclusively; dump fees, extra haul distances and time, changed haul routes, and haul road maintenance.

5.08 Load Restrictions. The Contractor shall be responsible for all damage to the work caused by the Contractor's hauling equipment. The Contractor shall comply with legal load restrictions when moving equipment or hauling materials on public roads that remains in service. A permit to operate an overweight, oversized, or over-width vehicle does not relieve the Contractor of liability for damage to public roads due

to the moving of equipment or materials.

The Contractor shall not allow loads on concrete pavement, base, or structures before the strength or time requirements for the concrete have been met. In case of pipes, the Contractor shall not allow loads before placing the specified cover fill.

6.00 RESPONSIBILBILTY FOR UTILITY PROCEDURES AND SERVICES

6.01 Location. Where underground main distribution conduits such as water, gas, sewer, electric power, telephone or cable are shown on the plans, the Contractor, for the purpose of preparing the Contractor’s bid, shall assume that every property parcel is served by a service connection for each type of utility. Failure by the Engineer to show the location of any utility on the plans shall not relieve the Contractor from the responsibilities below.

Before proceeding with the work, the Contractor shall confirm the final grade and locations of such facilities in accordance with the “Wyoming Underground Facilities Notification Act” and the “Wyoming High Voltage Power Lines and Safety Restrictions Act.”

The Contractor shall notify utility and pipeline companies of the proposed construction schedule at least two (2) Working Days before the start of work. The Contractor shall ask for the nature, location, and depth of pipes and cables and areas where they may conflict with the work. If a company cannot or will not provide this information, the Contractor shall obtain it by alternate means. Where conflicts may exist, the Contractor shall locate the relevant pipes or cables in three dimensions.

The Contractor shall not begin excavation until all such features have been located, their owners notified, and the Engineer has approved. The Contractor shall not interrupt the service function or disturb the supporting base of any utility without authority from the utility owner or an order from the City. Where protection is required to ensure support of utilities, the Contractor shall, unless otherwise provided, furnish and place the necessary protection at no cost to the City.

6.02. Utility Line Conflicts and Damage. If utility lines are determined to be in conflict with or are damaged during the work, the Contractor shall stop work in the immediate area, notify the Engineer and the utility owner, and cooperate with the owner to move or repair the utility. The Contractor shall be solely responsible for any damage done to such utilities due to failure to preserve original locate marks or to properly protect the utilities when their location is known.

7.00 WORK SCHEDULE AND CONDITIONS

7.01 Pre-Construction Conference. The Contractor will schedule and convene, at a mutually convenient time before the start of work, a Preconstruction Conference with, all Subcontractors, Design Engineer and/or City’s Representative, Board of Public Utilities, Power Company, Telephone Company, Gas Company, Cable Television, and other interested parties. Before or at the meeting, the Contractor shall provide the following, if applicable:

1. A letter providing the names, phone numbers and addresses, of material suppliers and Subcontractors;
2. Project Schedule in accordance with the item **7.05 Schedule** below;
3. Spill contingency and storm water pollution prevention plans in accordance with Standard Specification Section 01563 Erosion Control and Storm Water Management;
4. A traffic control plan in accordance with Section 01050 Traffic Control;
5. A list with names and phone numbers of key personnel, including the project superintendent and subordinates, authorized to sign contract documents and project records;
6. A list of phone numbers for the Contractor’s personnel the Engineer should call in case of emergency in accordance with item **4.05 Cooperation by the Contractor** above; and
7. Other items the Engineer may request.

7.02 Weekly Conference. Subsequently a representative of the Contractor and the Contractor’s Subcontractors (if requested) shall attend a weekly conference at a mutually convenient time and at a place designated by the City to review progress and discuss any problems that may arise or have incurred.

7.03 Work Progress. The Contractor shall make every effort to complete work in a manner and fashion that minimizes roadway closures and inconveniences to the traveling public and adjacent property owners. Progress will be continuously prosecuted on all roadways and drive approaches that have been closed for construction in accordance with Section 01041.1.01.I. of the Standard Specifications.

The Contractor shall not open up work to the prejudice or detriment of work already started. The City may require the Contractor to finish a section on which the work is in progress before work is started on any additional sections if the opening of such section is essential to public convenience.

7.04 Working Days and Time. Normal working hours shall be 7:00 am to 6:00 pm. No work shall be allowed on Saturdays without the City’s prior written permission. For the purposes of time limitations specified in these instructions, a Saturday shall count as a “Working Day” if the City has approved work on that Saturday. No work, except for City-approved emergency repairs, shall be allowed on Sundays or

Holidays. For the purposes of the time limitations in these instructions, neither a Sunday nor a Holiday will count as a “Working Day” even if the City has authorized emergency repairs to be performed on that Sunday or Holiday. If the Contractor desires to perform work beyond the City’s normal working hours, the Contractor must obtain the City’s written approval forty-eight (48) hours in advance of scheduled work. In an emergency situation, verbal approval will suffice until the next working day at which time written approval shall be obtained before further inspection work beyond normal working hours will be provided.

Holidays. Normal City holidays are as follows:

HOLIDAY	DATE
New Year’s Day	January 1 st
Martin Year’s Day	Third Monday in January
President’s Day	Third Monday in February
Memorial Day	Last Monday of May
Independence Day	July 4 th
Labor Day	First Monday in September
Veteran’s Day	November 11 th
Thanksgiving Day	Fourth Thursday in November
Day after Thanksgiving	Day after Thanksgiving
Christmas Day	December 25 th

With the Engineer’s prior written approval, no work shall be permitted the day before, during, and the day after said holidays. The Engineer may require the Contractor to cease construction operations at any other time if the Contractor’s operations are of such nature, the project is so located, or the traffic is of such volume that the Engineer deems it expedient to do so.

Frontier Days. During Cheyenne Frontier Days (CFD), typically the last full week in July, and the week immediately preceding, special rules shall apply in the following designated areas:

1. All roadways contained in the area bounded by 15th St. on the south, Snyder Ave. on the west, Pershing Blvd. on the north, and Van Lennen Ave. on the east, including the roadways making up the boundaries.
2. All roadways contained in the area bounded by Pershing Blvd. on the south, Interstate 25 on the west, the extensions of Manewal Dr. on the north, and Warren Ave./Yellowstone Rd. on the east, including the roadways making up the boundaries.
3. All roadways designated on the functional classification map as “Principal Arterial” or “Minor Arterial”.

4. All roadways located north of the Union Pacific Railroad tracks designated on the functional classification map as “Major Collector” or “Minor Collector”.

Functional classification maps are available from the Engineer’s Office or the Cheyenne Metropolitan Planning Organization’s website at www.plancheyenne.org.

During the week immediately preceding CFD, the special rules are as follows:

1. Work in the designated areas shall be in a state whereby all facilities are available to the public no later than 5 pm Wednesday of the week immediately preceding CFD;
2. After Wednesday of the week immediately preceding CFD, the only work allowed in designated areas are emergency repairs and operations having a duration of less than one (1) hour (including moving operations, such as striping or street sweeping).
3. All equipment, materials, traffic control devices, and other construction items shall be removed from the designated areas prior to 5 pm Wednesday of the week immediately preceding CFD.
4. All roadways and pedestrian ways shall be in such a condition that there shall be no interference with parades or other CFD event operations.

During CFD:

1. No work will be allowed in the designated areas with the exception of City-approved emergency repairs and moving operations, such as striping or street sweeping.
2. All moving operations must be approved in writing, in advance by the Engineer.
3. Work and traffic control operations can recommence during normal working hours on the Monday morning following the end of CFD.

Exceptions to the above will be made at the Engineer’s sole discretion.

7.05

Schedule. The Contractor shall submit a project schedule to the Engineer for review and discussion at the Pre-Construction meeting. This schedule shall be sufficiently detailed to show the following:

1. The activities needed to perform and complete the work, activities that might delay contract completion, and critical activities such as street closures or major traffic restrictions.

2. Sequence of each activity required to complete the project within the contract time allotted and in the manner specified. Interrelationships among activities shall be shown without lead or lag time.
3. The planned start and completion dates for each activity, the duration of each activity with activities of more than fifteen (15) Working Days in duration broken into two or more activities distinguished by location or some other feature.
4. Interim, milestone, and project completion dates specified in the contract.
5. An indication of how the schedule accommodates adverse weather days for each month.
6. Dates related to the procurement of materials, equipment, articles of special manufacture, etc.
7. Dates related to the submission of working drawings, plans, and other data specified for review or approval by the Engineer.
8. Dates related to required special inspections of structural steel fabrications and other specified activities by the City or third parties.

The Contractor shall submit monthly updates to the Project Schedule at the time of the submittal of the monthly Pay Estimate. The schedule update shall include any revised planned start and finish dates for each activity shown on the most recent accepted schedule. For newly started or finished activities, the Contractor shall include the actual start or finish date. For activities previously started and still ongoing, the Contractor shall show the remaining duration and planned finish dates. The City may withhold processing the monthly Pay Estimate until the Contractor submits the monthly update to the Project Schedule.

The Engineer may request a schedule revision at any time for any reason. Circumstances leading to such a request include, but are not limited to, the following:

1. A delay (actual or projected) of partial or contract completion dates by fourteen (14) calendar days or more;
2. A difference between the actual rate of progress and that depicted in the schedule; and
3. Issuance of a contract modification that, by adding, deleting, or revising activities, changes the planned sequence of work or the method and manner of its performance.

7.06 Requirements for Workers, Methods, and Equipment. The Contractor shall at all times provide enough qualified labor and enough capable equipment to complete the project in accordance with the contract.

The Contractor shall provide workers that are sufficiently skilled to perform the work assigned to them. In writing, the City may direct removal from the project of any person, regardless of employer, who is unsafe, incompetent, intemperate, disorderly, or insubordinate. Through written notice, the City may suspend the work for failure of the Contractor to comply with such a directive or for failure to provide enough qualified workers.

All equipment proposed to be used on the work shall be of sufficient size and in such mechanical condition as to meet requirements of the work and to produce a satisfactory quality of work. Equipment used on any portion of the project shall be such that no injury to the roadway, adjacent property, or other improvement will result from its use.

When the methods and equipment to be used by the Contractor in accomplishing the construction are not prescribed in the contract, the Contractor is free to use any methods or equipment that the Contractor demonstrates to the satisfaction of the Engineer will accomplish the contract work in conformity with the requirements of the contract. When the contract specifies that the construction be performed by the use of certain methods and equipment, such methods and equipment shall be used unless others are authorized by the Engineer.

If the Contractor desires to use methods or types of equipment other than those specified in the contract, the Contractor may request authority from the Engineer to do so. The request shall be in writing and shall include a full description of the methods and equipment proposed to be used and an explanation of the reasons for desiring to make the change. Approval does not relieve the Contractor from the requirement to produce work in accordance with the contract documents. The use of alternative methods or equipment resulting in work that fails to meet contract requirements may lead the Engineer to, in writing:

1. Direct a stop in their use;
2. Order the completion of remaining work using the original specified methods or equipment; or
3. Require the removal, at no additional cost to the City, of the unsatisfactory work and its replacement using the original specified methods and equipment.

7.07 Suspension of Work. The City shall have the authority to suspend the work wholly or in part, for such period as may be deemed necessary due to unsuitable weather, due to such other conditions as are considered unfavorable for the suitable prosecution of the work, for failure of the Contractor to correct unsafe conditions,

for failure of the Contractor to carry out orders given, or for failure of the Contractor to perform any provision of the contract.

If the City suspends the work for more than ninety (90) days, through no fault of the Contractor, the Contractor may apply, in writing, for a price adjustment to compensate for reasonable expenses caused by the suspension. Any application for price adjustment or contract time extension will be submitted to the governing body of the City for its consideration in the form of a Contract Modification. It will be the responsibility of the Contractor to provide sufficient documentation to substantiate any claim.

The City will not grant or consider contract modifications based upon City-ordered suspension:

1. Without timely written notice from the Contractor;
2. To the extent that the suspension is overlapped or falls within a suspension or delay due to any other cause, including delays caused by the Contractor; or
3. That includes profit.

The Contractor may ask the City to suspend the project in writing due to unsuitable weather or due to such other conditions as are considered unfavorable for the suitable prosecution of the work. The Contractor shall not suspend operations or remove necessary equipment or materials without approval from the City.

During delays or suspensions, if the traveling surface is a leveling course or non-paved surface, the Contractor shall maintain the roadway for traffic use (including snow removal and placing of sand) and the quality of the surface course until the placement of additional course or temporary surfacing, at no additional cost to the City. If placement of concrete pavement or a full lift of plant mix pavement is not completed before delays or suspension of work, the Contractor shall provide, place, and maintain the temporary plant mix pavement and then remove it at the end of the suspension.

During suspensions, the Contractor shall store materials and equipment, at no additional cost to the City as far from the travel way as possible; at a location that will not cause maintenance or safety problems for the roadway; and at a location where they will be protected from damage. The Contractor shall maintain all living material in new plantings, seeding, and sods in an acceptable growing condition and protect from injury, at no additional cost to the City.

During suspensions, the Contractor shall provide roadway drainage, temporary structures needed for public travel throughout the project, any required temporary traffic control, along with removal of such temporary structures, traffic control, and surfacing, at the end of the suspension at no additional cost to the City. Before

suspension, the Contractor shall protect slopes without vegetation in accordance with Section 01563 Erosion Control and Storm Water Management.

If during a suspension the Contractor fails to accommodate traffic or maintain the project, including temporary traffic control devices, the Engineer may direct other organizations to do so. The City shall deduct the cost from monies due the Contractor or bill the Contractor, as appropriate.

During suspensions, the Contractor shall complete necessary measures to protect the work and the roadway during the suspension. The Contractor shall repair or replace materials lost or damaged during the suspension at no additional cost to the City.

The Contractor shall resume work when conditions are favorable or when approved by the Engineer.

7.08 Extension of Contract Completion Date. The contract time for completion shall be fixed by the City and stated in the Contract Agreement, either as a calendar date or as a specified number of calendar days.

The Contractor shall perform the work in an acceptable manner within the time stated in the contract except that the contract time for completion may be adjusted as follows:

1. If the satisfactory completion of the contract shall require performance of work in greater quantities than those set forth in the proposal, the time allowed for performance shall be increased in the same ratio as the final estimate bears to the original contract amount, except that the final monetary amount of any contract modification for which an extension of contract time was previously allowed shall be deducted from the final estimate prior to making the pro-rata time adjustment.
2. If delays beyond the Contractor's control are caused solely by action or inaction by the City, or are for unforeseen causes beyond the control and without fault or negligence of the Contractor, such delays will entitle the Contractor to an extension of time which will be based upon the effect of delays to the project as a whole and will not be granted for non-controlling delays to minor included portions of work, unless it can be shown that such delays did, in fact, delay the progress of the project as a whole. Written request for such extension of time must be made by the Contractor within ten (10) calendar days after the beginning of such delay.

No allowance shall be made for delay or suspension of the work due to fault of the Contractor. Nor will the City grant an extension based on pleas that the contract specified insufficient time for completion of the project.

7.09 Concurrent Delays. Concurrent delays are delays occurring at the same time to separate critical activities. When concurrent delays occur, the City will use only the

longer delay, and/or the excusable delay, to determine extensions to the contract completion date. Non-excusable delays will not be considered for extensions.

7.10 Weather Days. The Adverse Weather Table shows the number of working days included in the contract time in anticipation of weather that may preclude work. If the Contractor believes that it is entitled to additional time for adverse weather, the Contractor must submit written documentation to the Engineer and City within five (5) working days of the end of month that adverse weather was experienced. The Engineer may extend the completion date if the actual number of adverse weather days exceeds the expected number and the Contractor has pursued the work diligently during the month. The determination as to whether a day is to be considered an adverse weather day shall be at the discretion of the Engineer for when work on critical path items cannot be accomplished. The Engineer shall not count or treat Sundays or holidays as adverse weather days. Any weather days not used during any month are invalid and cannot be considered cumulative. For partial months, the Engineer shall prorate the number of expected lost workdays due to adverse weather.

ADVERSE WEATHER TABLE

<u>MONTH</u>	<u>DAYS</u>	<u>MONTH</u>	<u>DAYS</u>	<u>MONTH</u>	<u>DAYS</u>
January	8	May	4	September	2
February	8	June	3	October	4
March	7	July	2	November	5
April	6	August	2	December	7

8.00 MEASUREMENT AND PAYMENT

8.01 Measurement of Quantities. The Engineer shall measure pay items in the units of measure specified in the contract using methods of measurement and computation that meet generally recognized good engineering practice. The Engineer shall measure pay items when in place and complete. The actual work performed shall be measured, excluding work outside the construction limits unless adjusted by the City. The Engineer shall measure pay item quantities using the following methods, unless otherwise provided elsewhere in the contract documents:

1. Area. Computed from linear distances measured horizontally. Individual fixtures occupying areas equal to or less than 9 sq. ft. shall not be deducted from the computation.
2. Linear. Items measured by the foot shall be measured parallel to the surface on which the items are installed.
3. Lump Sum. Although actual quantities of the components in a lump sum pay item used in the work may differ from the estimated quantities specified, the City will not change the amount of payment.

4. Volumes of Excavation, Embankment, and Similar Pay Items. The average end area method shall be used unless otherwise specified or agreed to.
5. Asphalt Materials. Measured by the gallon or short ton, subject to correction for foaming, shipping loss, or other reasons for nonuse.
6. Delivery Tickets. All delivery tickets that are required for the purpose of calculating quantities for payment must be received by the Engineer at the time of delivery. Payment shall not be made for delivery tickets which do not show type of material, gross weight, tare weight, truck number, and date. Delivery tickets shall utilize automatic printer systems. Scale certification shall be submitted before their use. In no case shall materials weighed on non-certified scales be accepted for payment.

8.02 Compensation for Altered Quantities. Unless otherwise provided, payments to the Contractor shall be made for the actual quantities of contract items performed in accordance with the plans and specifications, and if, upon completion of the construction, these actual quantities show either an increase or decrease from quantities given in the bid schedule, the contract unit prices shall still prevail. Except as provided otherwise, the City shall not allow for increased expense, loss of expected reimbursement, or loss of anticipated profits suffered or claimed by the Contractor from any cause, including directly from alterations or indirectly from unbalanced allocation by the bidder of overhead expense among the pay items.

8.03 Monthly Progress Payment. The City shall make payments at least once each month in accordance with Article 4. Compensation and Method of Payment of the Contract Agreement as work progresses. The Contractor shall supply supporting billing documentation, including as a minimum, a spreadsheet (form to be approved by the Engineer) which lists each item of work included in the Bid Proposal form and shows quantities and amounts currently being invoiced and previously invoiced. Payments shall be based on the Engineer's approval of the estimate of the value of work performed and materials complete-in-place, in accordance with the contract, and for materials delivered, in accordance with item **8.04 Payment for Material on Hand** below.

8.04 Payment for Material on Hand. The City may pay for materials stockpiled or stored for later use on the project and for which the Contractor provides acceptable documentation indicating the materials meet contract requirements. Stockpiled or stored materials may be located on the project or at facilities approved by the City, which the City reserves the right to inspect. Materials shall be stored in accordance with manufacturer's recommendations. The City shall not make such payment without a written request received at least ten (10) calendar days before the date of the next scheduled progress payment, and in no case will it pay more than fifty (50) percent of the item's original bid extension. The Contractor shall include with the written request documentation, such as copies of invoices, freight bills, or other information required by the Engineer, that supports material and shipping costs.

9.00 MOBILIZATION

Payment shall be made for mobilization to cover the costs of preparatory work and operations including but not limited to those necessary for the movement of personnel, equipment, supplies and incidentals to the project site; for the establishment of all field offices, storage buildings, and other facilities necessary for the work on the project, and for all other work and operations which must be performed, or costs incurred, prior to beginning work on the various items on the project.

Mobilization shall be measured on a lump sum basis and payment shall be made with the monthly estimate based on the percentage of the original contract amount earned in accordance with the following:

1. On the first estimate following award, 10 percent of the Mobilization pay item or 1 percent of the original contract amount, whichever is less will be paid.
2. When 5 percent of the original contract amount is earned, 25 percent of the amount bid for Mobilization or 2 percent of the original contract amount, whichever is less will be paid.
3. When 10 percent of the original contract amount is earned, 50 percent of the amount bid for Mobilization or 5 percent of the original contract amount, whichever is less will be paid.
4. When 25 percent of the original contract amount is earned, 60 percent of the amount bid for Mobilization or 6 percent of the original contract amount, whichever is less will be paid.
5. When 50 percent of the original contract amount is earned, 70 percent of the amount bid for Mobilization or 7 percent of the original contract amount, whichever is less will be paid.
6. When 70 percent of the original contract amount is earned, 100 percent of the amount bid for Mobilization or 10 percent of the original contract amount, whichever is less will be paid.
7. Upon completion of all work on the project, payment on any amount bid for Mobilization in excess of 10 percent of the original contract amount will be paid.

The total sum of all payments will not exceed the original contract amount bid for Mobilization, regardless of the fact that the contractor may have shut down work on the project or moved equipment away from the project and then back again.

Mobilization is subject to the retainage that shall be withheld for final payment.

The payment schedule for mobilization shall be utilized for construction staking, contractor materials testing, and similar items, when the method of measurement and basis of payment is not otherwise specified in the contract documents.